

Miniature ball rail systems

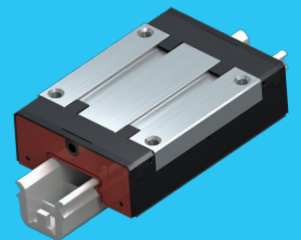
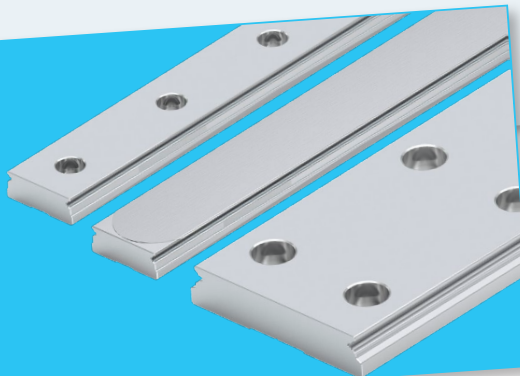
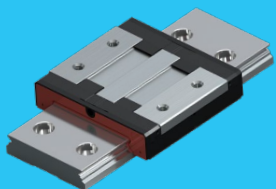
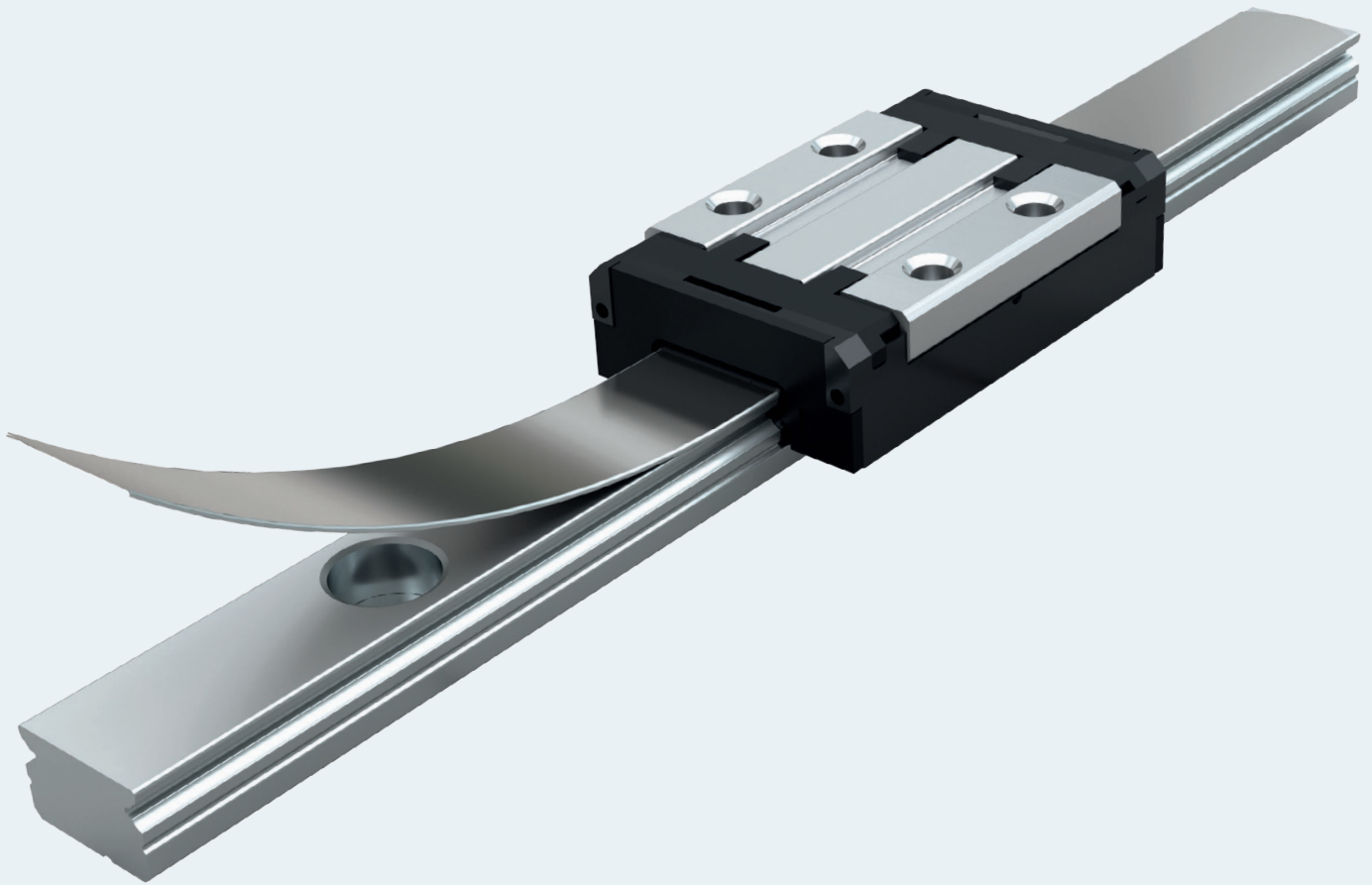

Miniature ball rail systems

News at a glance	3
Product overview	4
General technical data and calculations	6
Technical data	10
Mounting instructions	15
SNS – slimline, normal, standard height, R0442	16
SLS – slimline, long, standard height, R0444	18
SNS – standard, miniature ball guide rail without / with cover strip R0445	20
BNS – wide, normal, standard height, R0443	22
BLS – wide, long, standard height, R0441	24
BNS – wide, miniature ball guide rail without / with cover strip R0455	26
Accessories	28
Start-up and maintenance	30
Lubrication quantities and methods	32
Further information	34

News at a glance

Runner block and guide rail configurator

With the new configurators, Bosch Rexroth accelerates the selection and configuration of ball runner blocks and ball guide rails. A built-in plausibility check monitors each decision in real time to ensure that the individual configuration can be implemented. Then the selected components can be ordered directly from the Bosch Rexroth eShop.

[Link to the runner block configurator](#)

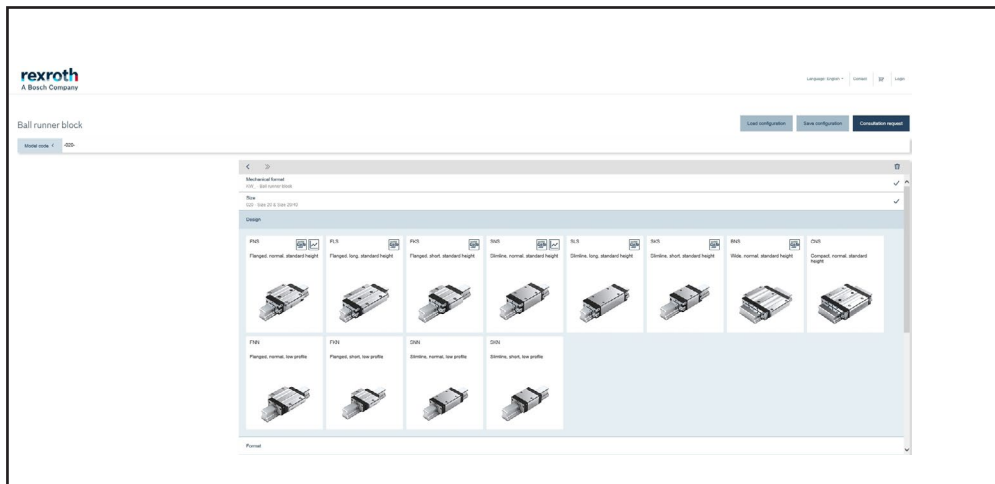

[Link to the guide rail configurator](#)

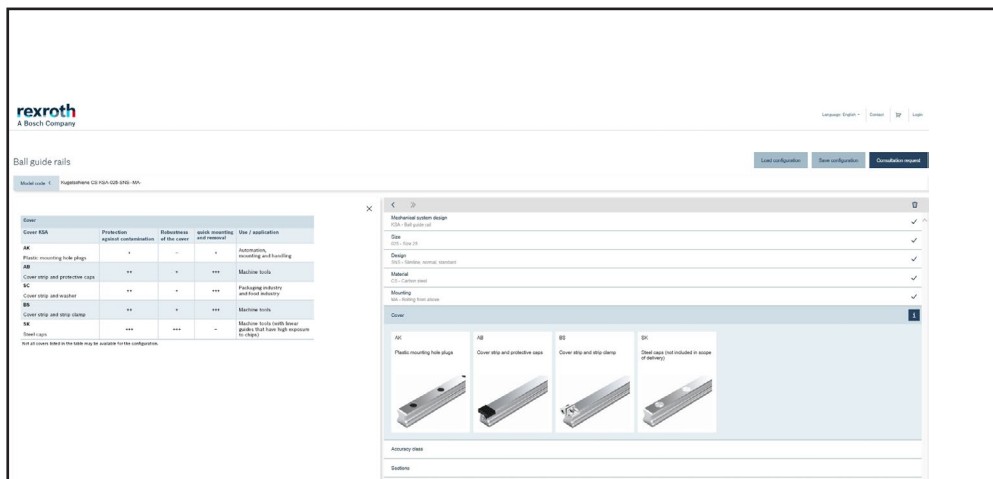

Product overview

The miniature version of the ball rail systems has been developed for a variety of applications which require ball-bearing longitudinal guides with extremely small size and high load-bearing capacity:

- ▶ Textile machinery
- ▶ Laboratory automation
- ▶ Medical technology
- ▶ Automation technology
- ▶ Fine mechanics
- ▶ Handling and robotics
- ▶ Semiconductor industry
- ▶ Optical industry

The guide units have exactly the same load ratings in all four high load directions, high load-bearing capacity in all directions of load, including high load torques about all axes, due to a design of largest possible ball sizes. They are characterized by optimal discharge and low friction.

From size 15 onwards, there is a lubricating nipple on the face and a lateral relubrication option.

Optionally available from size 9 is a cover strip made of stainless steel to close the fixing holes.

All steel parts of the runner block and the guide rail are made of corrosion-resistant, martensitic steel.

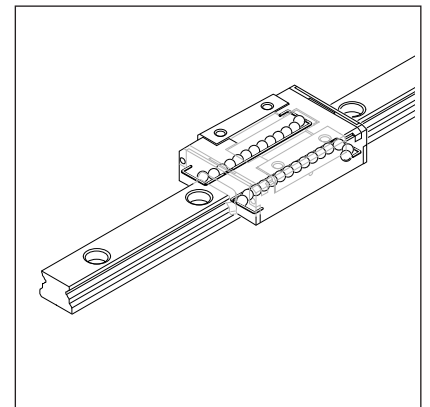
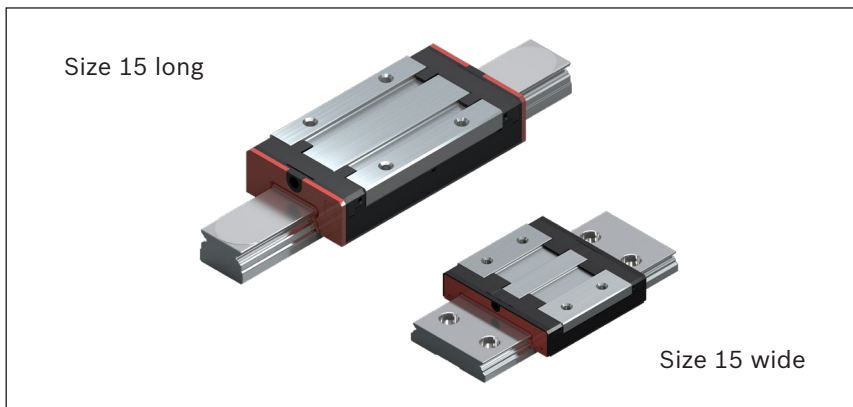
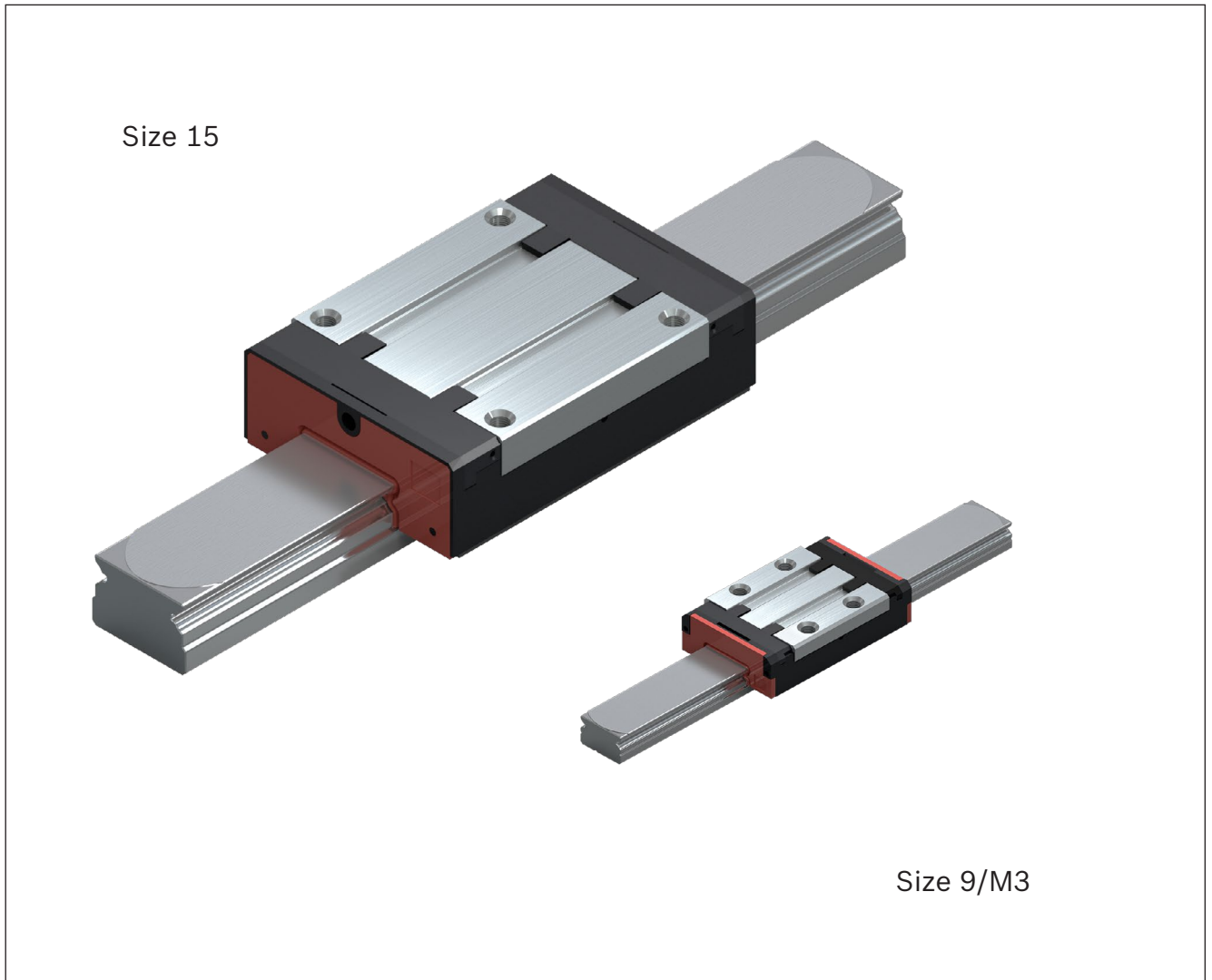

- Accuracy classes P, H and N
- Built-in lube ports
- Smooth running thanks to optimized ball recirculation and guidance

- Easy mounting due to ball retention

General technical data and calculations

Definition of dynamic load capacity

The radial loading of constant magnitude and direction which a linear rolling bearing can theoretically endure for a

nominal life of 10^5 meters distance traveled (as per DIN 636 Part 2).

Definition of static load capacity

The static loading in the direction of load which corresponds to a calculated stress of 4200 Mpa at the center of the most heavily loaded rolling-element/raceway (rail) contact with a ball conformity of $f_r \leq 0.52$, and 4600 Mpa with a ball conformity of $f_r \geq 0.6$.

Note:
With this contact stress, a permanent overall deformation of the rolling element and the raceway will occur at the contact point corresponding to approx. 0.0001 times the rolling element diameter (as per DIN 636 Part 2).

Definition and calculation of the nominal life

The calculated service life which an individual linear rolling bearing, or a group of apparently identical rolling element bearings operating under the same conditions, can attain with a

90% probability, with contemporary, commonly used materials and manufacturing quality under conventional operating conditions (to DIN 636 Part 2).

Calculate the nominal life L or L_h according to formula (1), (2) or (3):

Nominal life at constant speed

$$(1) \quad L = \left(\frac{C}{F_m} \right)^3 \cdot 10^5$$

$$(2) \quad L_h = \frac{L}{2 \cdot s \cdot n_s \cdot 60}$$

- C = dynamic load capacity (N)
- F_m = equivalent dynamic load (N)
- L = nominal life (m)
- L_h = nominal life (h)
- n_s = stroke repetition rate (full cycles) (min^{-1})
- $q_{t1}, q_{t2} \dots q_{tn}$ = discrete time steps for $v_1, v_2 \dots v_n$ (%)
- s = length of stroke (m)
- $v_1, v_2 \dots v_n$ = travel speeds (m/s)
- v_m = average speed (m/s)

Nominal life at variable speed

$$(3) \quad L_h = \frac{L}{3600 \cdot v_m}$$

$$(4) \quad v_m = \frac{q_{t1} \cdot |v_1| + q_{t2} \cdot |v_2| + \dots + q_{tn} \cdot v_n}{100\%}$$

Equivalent dynamic load on bearing for calculation of service life

If the bearing is subject to variable loads, the equivalent dynamic load F_m must be calculated according to formula (5):

F_m = equivalent dynamic load (N)
 $F_{eff1}, F_{eff2} \dots F_{effn}$ = discrete load steps (N)
 $q_{s1}, q_{s2} \dots q_{sn}$ = discrete travel steps for $F_{eff1}, F_{eff2} \dots F_{effn}$ (%)

For variable load on bearing

$$(5) \quad F_m = \sqrt[3]{|F_{eff1}|^3 \cdot \frac{q_{s1}}{100\%} + |F_{eff2}|^3 \cdot \frac{q_{s2}}{100\%} + \dots + |F_{effn}|^3 \cdot \frac{q_{sn}}{100\%}}$$

For combined load on bearing

The combined equivalent load on bearing F_{comb} resulting from combined vertical and horizontal external loads is calculated according to formula (6):

Note:

The structure of the Ball Rail System permits this simplified calculation.

$$(6) \quad F_{comb} = |F_y| + |F_z|$$

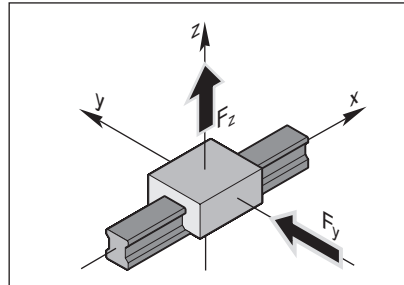

C = dynamic load capacity²⁾ (N)
 F_{comb} = combined equivalent load on bearing (N)
 F_y, F_z = dyn. external loads¹⁾ (N)
 M_L = dyn. longitudinal moment load capacity²⁾ (Nm)
 M_t = dyn. torsional moment load capacity²⁾ (Nm)
 M_x = dyn. torsional moment about the x-axis (Nm)
 M_y = dyn. longitudinal moment load about the y-axis (Nm)
 M_z = dyn. longitudinal moment load about the z-axis (Nm)

For combined load on the bearing in conjunction with a torsional moment

The combined equivalent load on bearing F_{comb} resulting from combined vertical and horizontal external loads in conjunction with a torsional moment is calculated according to formula (7):

Formula (7) applies only when using a single guide rail.

$$(7) \quad F_{comb} = |F_y| + |F_z| + C \cdot \frac{|M_x|}{M_t} + C \cdot \frac{|M_y|}{M_L} + C \cdot \frac{|M_z|}{M_L}$$

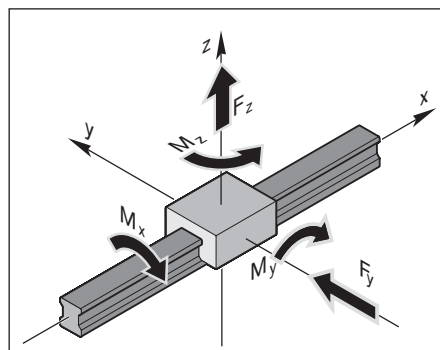

General technical data and calculations

Equivalent static load on bearing

For combined static external loads – vertical and horizontal – in conjunction with a static torsional moment load, calculate the combined equivalent static load on the bearing F_{0comb} using formula (8). The combined equivalent static load on the bearing F_{0comb} must not exceed the static load capacity C_0 .

Formula (8) applies only when using a single guide rail.

$$(8) F_{0comb} = |F_{0y}| + |F_{0z}| + C_0 \cdot \frac{|M_{0x}|}{M_{t0}} + C_0 \cdot \frac{|M_{0y}|}{M_{L0}} + C_0 \cdot \frac{|M_{0z}|}{M_{L0}}$$

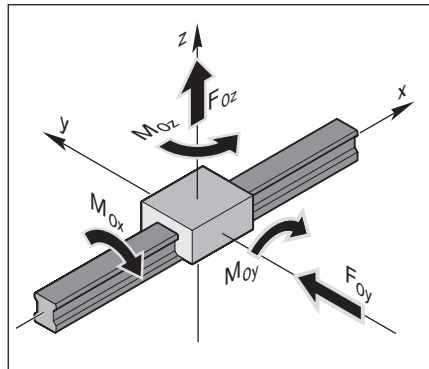

C_0	= static load capacity ²⁾	(N)
F_{0comb}	= combined equivalent load on bearing	(N)
F_{0y}, F_{0z}	= stat. external load ¹⁾	(N)
M_{0x}	= stat. torsional moment load about the x-axis	(Nm)
M_{0y}	= stat. longitudinal moment load about the y-axis	(Nm)
M_{0z}	= stat. longitudinal moment load about the z-axis	(Nm)
M_{t0}	= stat. torsional moment load ²⁾	(Nm)
M_{L0}	= stat. longitudinal moment load ²⁾	(Nm)

1) An external load acting at an angle on the runner block is to be broken down into its F_y and F_z components, and these values are then to be used in formula.

2) See tables

Static load safety factor S_0

You must verify mathematically any structural design involving rolling contact with regard to the static load safety factor. The static load safety factor for a linear guide results from the following equation:

$$S_0 = \frac{C_0}{F_{0\max}}$$

- S_0 = static load safety factor
 C_0 = static load capacity (N)
 $F_{0\max}$ = maximum static load (N)

In this connection, $F_{0\max}$ represents the maximum load amplitude that can occur, which can affect the linear guide. It does not matter whether this load is exerted only for a short period. It may represent the peak amplitude of an overall dynamic loading. For dimensioning, the data shown in the table applies.

Static load safety factor S_0	Conditions of use
Overhead hanging arrangements or applications with serious potential risks	≥ 12
High dynamic load when at standstill, contamination.	8 – 12
Normal dimensioning of machinery and plant without full knowledge of the load parameters or connection details.	5 – 8
Full knowledge of all the load data. Vibration-free operation is ensured.	3 – 5

Technical data

Travel speed

$$v_{\max} = 3 \text{ m/s}$$

Speeds of up to 5 m/s are possible.
Service life is limited by wear of plastic parts.

Acceleration

$$a_{\max} = 250 \text{ m/s}^2$$

Only with preloaded systems.
For non-preloaded systems:
 $a_{\max} = 50 \text{ m/s}^2$

Operating temperature range

$$-10 \text{ }^\circ\text{C} \dots 80 \text{ }^\circ\text{C}$$

Brief peaks up to 100 °C are permissible.

Accuracy classes and their tolerances (μm)

Miniature ball rail systems are offered in 3 different accuracy classes.

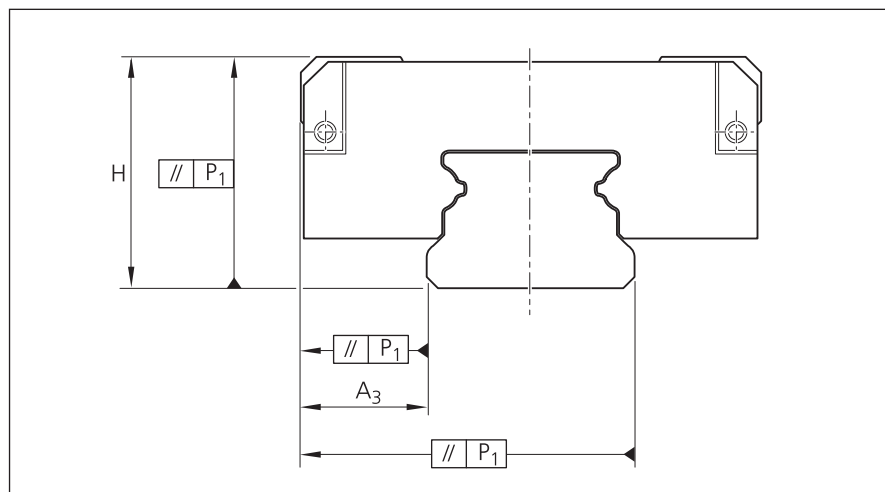

Accuracy class	Dimensional tolerance (μm)		Max. difference in dimensions H and A ₃ on the same rail $\Delta H, \Delta A_3$ (μm)
	H	A ₃	
P	± 10	± 10	7
H	± 20	± 20	15
N	± 30	± 30	20

Measured at middle of runner block ¹⁾	For any block/rail combination at any position on rail	For different runner blocks at same position on rail
--	--	--

1) For dimensions H and ΔH , the middle of the runner block is calculated from the mean of the two measuring points shown.

Parallelism offset P_1 of the ball rail system in service

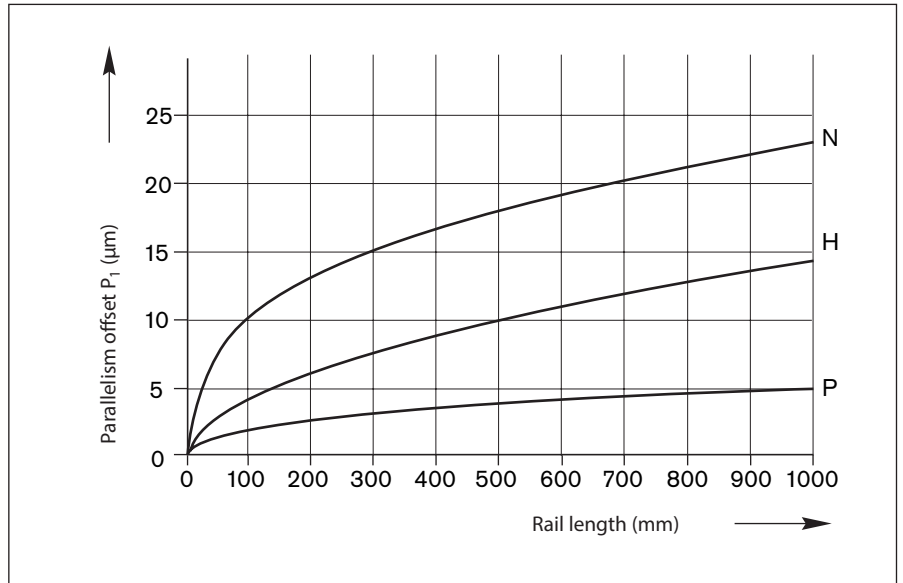

Parallelism offset of the installed rails measured on the guide rails and on the runner blocks

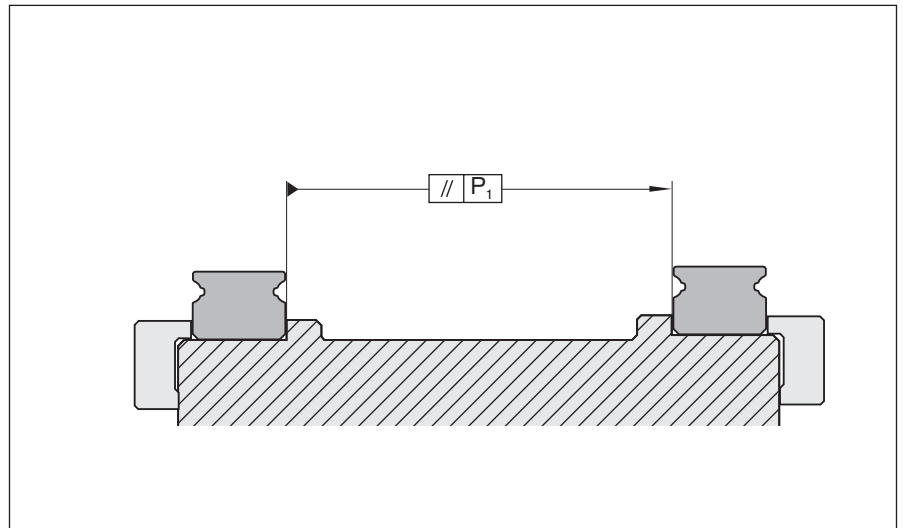

Size	Parallelism offset P_1 (mm)	
	Clearance	Preload
Standard guide rails R0445		
7	0.004	0.002
9/M3	0.005	0.002
12	0.008	0.004
15	0.017	0.008
20	0.025	0.016
Wide guide rails R0455		
9/M3	0.010	0.004
12 B	0.014	0.006
15 B	0.018	0.011

Technical data

Vertical offset

Permissible vertical offset in transverse direction S_1
 The permissible vertical offset S_1 includes the tolerance for dimension H (see accuracy classes).

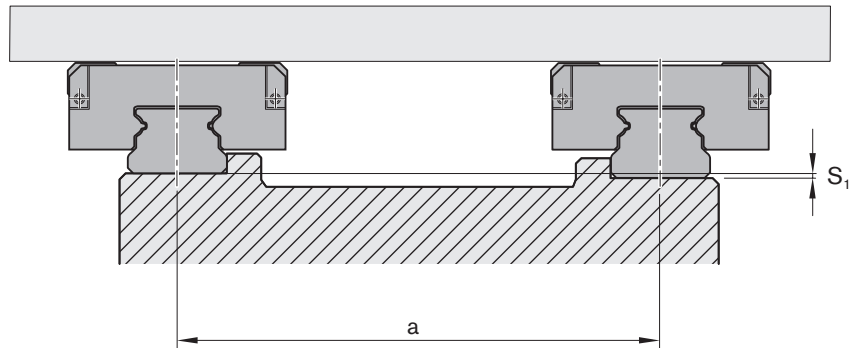

$$S_1 = a \cdot Y$$

- S_1 = permissible vertical offset (mm)
- a = distance between guide rails (mm)
- Y = calculation factor

Calculation factor	For preload class	Clearance	Preload
Y		$3.0 \cdot 10^{-4}$	$1.5 \cdot 10^{-4}$

Permissible vertical offset in longitudinal direction S_2
 The permissible vertical offset S_2 includes the tolerance "max difference of dimension H on the same rail" ΔH (see accuracy classes).

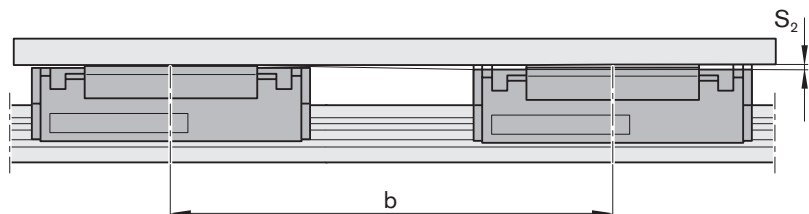

$$S_2 = b \cdot 7 \cdot 10^{-5}$$

- S_2 = permissible vertical offset (mm)
- b = distance between runner blocks (mm)

Preload and clearance

Preload class	Accuracy class			
	P 1	H 9	N 9	
Preload and clearance	~0 to moderate preload	~0 to moderate preload	~0 to moderate clearance	Moderate clearance to moderate preload

Markings on runner block and guide rail

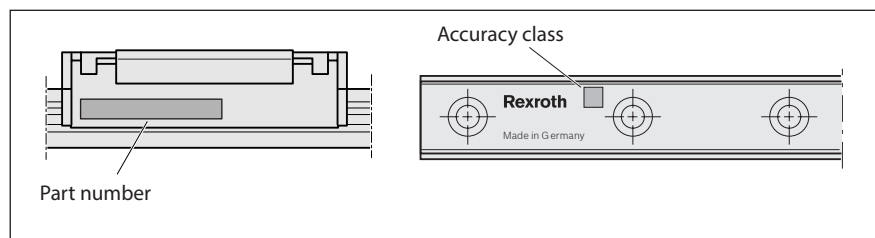

Rigidity of the miniature ball rail system when preloaded
 Runner block mounted with 4 screws, strength class 12.9

Standard runner block R0442

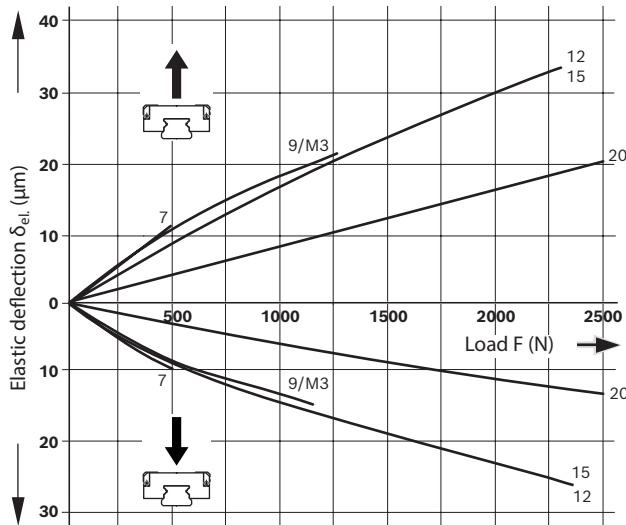

Wide runner block R0443

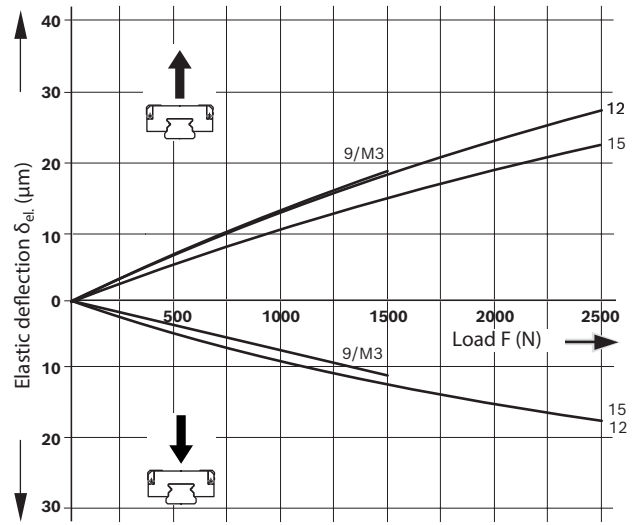

Long runner block R0444

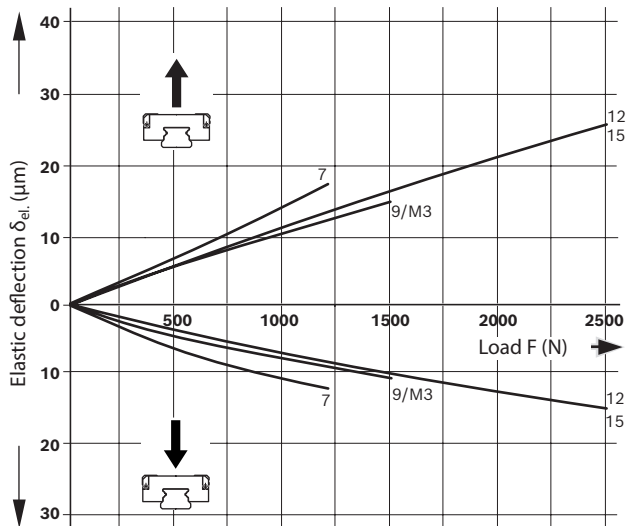

Wide, long runner block R0441

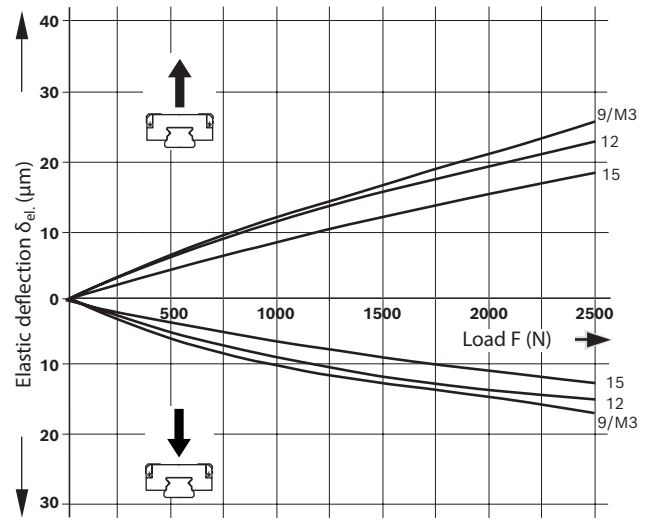

Technical data

General Notes

The screw connections specified in the DIN 645-1 standard can be overstressed due to the high performance capability of profiled rail systems. The most critical point is the screw connection between the guide rail and the mounting base. If the lift-off loads (F) or moments (M_t) are higher than the respective load values given in the table, the screw connections must be recalculated separately.

The data applies for the following conditions:

- Mounting screw quality 12.9
- Screws tightened using a torque wrench
- Screws lightly oiled
(For screws in quality 8.8, an approximation factor of 0.6 can be applied)

Miniature ball rail systems

Guide Rails	Runner blocks R0442			Runner blocks R0444	
	Size	F_{max} (N)	M_{tmax} (Nm)	F_{max} (N)	M_{tmax} (Nm)
R0445	7	1000	3.2	1150	3.7
	12	–	–	4300	23.7
	15	3740	26.0	4280	30.0
	No restriction for sizes				
R0445	R0442:	9/M3, 12 and 20			
	R0444:	9/M3			
R0455	R0441,R0443:	9/M3, 12 and 15			

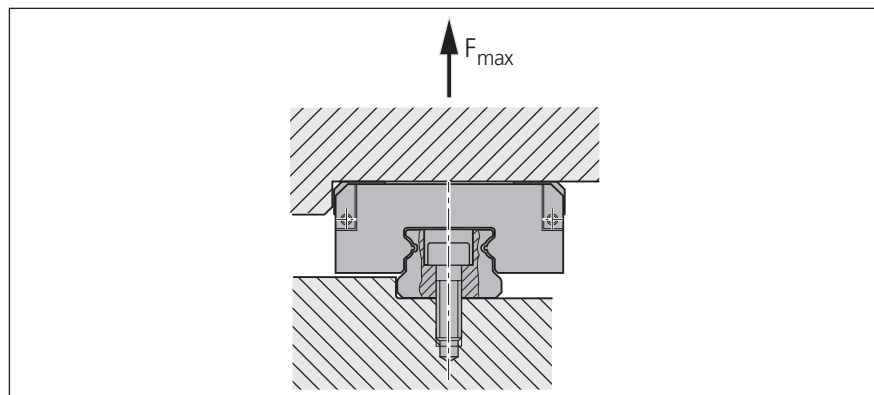

Friction and seals

The total friction force of the runner blocks is made up of the "runner block friction force" and the "seal friction force". For special applications with a defined displacement force, the runner block and guide rail are matched to each other. Runner blocks are pushed onto the guide rail and supplied as a unit.

The runner blocks are equipped with low-friction seals as standard (limited wiping action at very low friction force).

Part number: R044. ... 01

(See tables "Runner block part numbers")

Optionally runner block with N-seal:

The runner blocks are also available with N-seal (very good wiping action with increased friction force).

Part number: R044. ... 00

(Otherwise as tables "Runner block part numbers")

Sizes 15, 20, 9/M3 wide, 12 wide, 15 wide and long runner blocks of sizes 9/M3, 12 and 15, additionally completely sealed with longitudinal seal.

Friction

The friction coefficient μ of Rexroth's miniature ball rail system is approximately 0.002 to 0.003 (without the friction of the seal).

Mounting instructions

Reference edges, corner radii, screw sizes and tightening torques

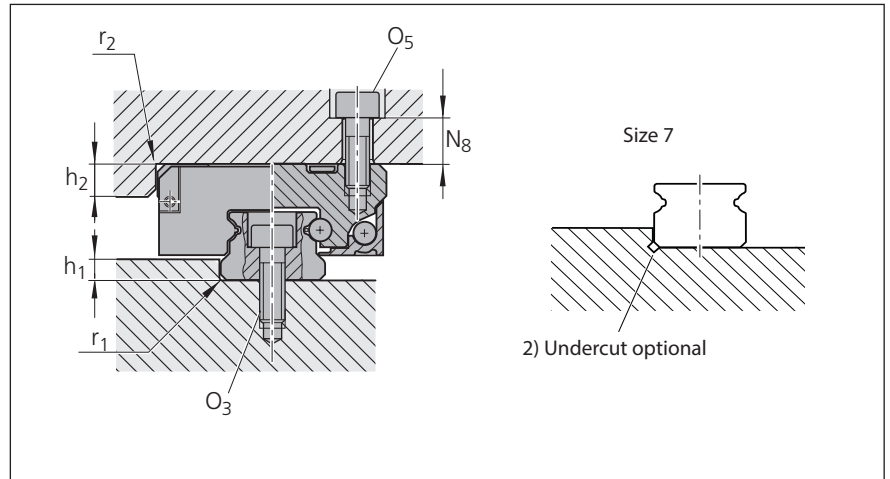

Size	h ₁ (mm)	r ₁ max. (mm)	h ₂ (mm)	r ₂ max. (mm)	O ₅ ISO 4762 ¹⁾ 4 pcs.	O ₃ ISO 4762 ¹⁾ (rail)	N ₈ (mm)
Standard runner block R0442							
7	1.2 _{-0.1}	0.1 ²⁾	2.2	0.3	M2x5	M2x5	3.0
9/M3	1.5 _{-0.2}	0.3	2.5	0.3	M3x8	M3x8	5.0
12	2.5 _{-0.5}	0.3	3.5	0.5	M3x8	M3x8	5.0
15	2.8 _{-0.5}	0.5	4.5	0.5	M3x8	M3x10	4.5
20	6.3 _{-0.5}	0.5	6.5	0.5	M4x12	M5x14	6.5
Long runner block R0444							
7	1.2 _{-0.1}	0.1 ²⁾	2.2	0.3	M2x5	M2x5	3.0
9/M3	1.0 _{-0.1}	0.3	2.5	0.3	M3x8	M3x8	5.0
12	2.0 _{-0.2}	0.3	3.5	0.5	M3x8	M3x8	5.0
15	2.8 _{-0.5}	0.5	4.5	0.5	M3x8	M3x10	4.5
Wide runner block R0443; wide, long R0441							
9/M3	1.8 _{-0.2}	0.3	2.5	0.3	M3x8	M3x8	5.5
12	2.8 _{-0.5}	0.5	3.0	0.4	M3x8	M4x10	4.5
15	2.8 _{-0.5}	0.5	4.5	0.5	M4x10	M4x12	6.0

1) Formerly DIN 912

Tightening torques for the mounting screws

$\mu K = \mu G = 0.125$

8.8 Nm	M2	M3	M4	M5
	A2-70 12.9	0.35 0.50	1.1 2.1	2.0 4.6

Note on installation

The runner blocks are delivered mounted on a plastic arbor.

- Position the runner block complete with the arbor at the head of the rail and push on; the arbor will thus be pushed out of the runner block.

When removing the runner block, carry out the above operations in reverse sequence.

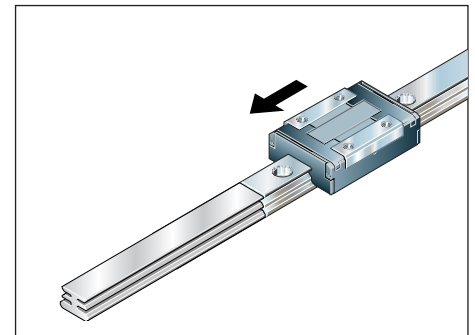
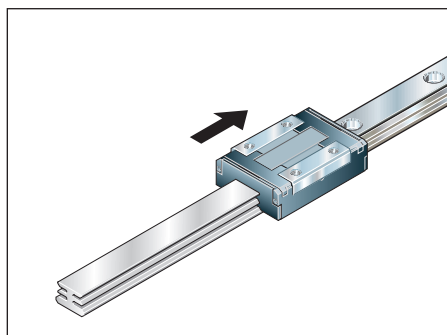

SNS – slimline, normal, standard height, R0442

All steel parts of the runner block are made of corrosion-resistant, martensitic steel.
The runner blocks are delivered mounted on arbors.

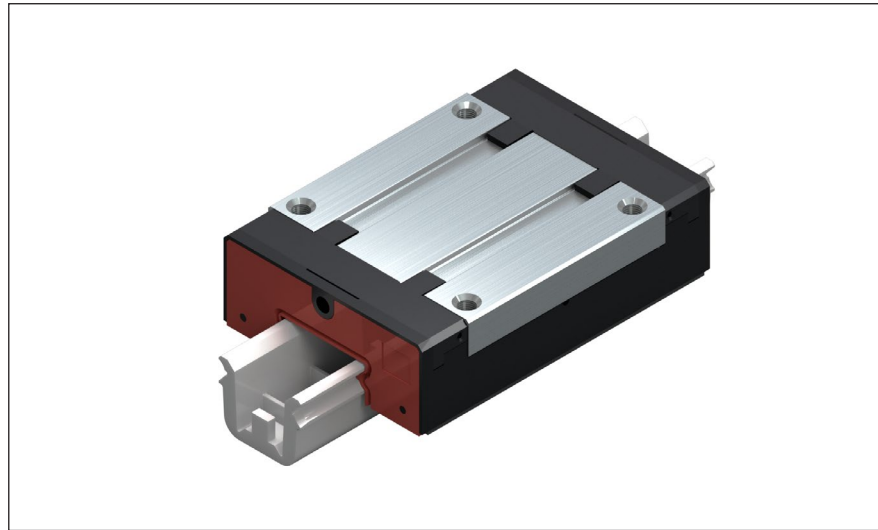

Part numbers for runner blocks

Standard seals: low-friction seals.

Part number: R0442 ... 01

(see table)

Special versions:

Runner blocks are also available:

- with N seals
(excellent wiping action)
Sizes 15 and 20 have additional longitudinal seals for full sealing.
Part number: R0442 ... 00
(otherwise as per table)
- without basic lubrication for individual lubrication.
 - sizes 15 and 20 additionally with N seals and longitudinal seals
Part number: R0442 ... 40
(otherwise as per table)
 - with low-friction seals
Part number: R0442 ... 41
(otherwise as per table)

Size	Accuracy class	Part numbers for runner blocks	
		Clearance	Preload
7	P	-	R0442 712 01
	H	R0442 793 01	R0442 713 01
	N	R0442 794 01	-
9/M3	P	-	R0442 812 01
	H	R0442 893 01	R0442 813 01
	N	R0442 894 01	-
12	P	-	R0442 212 01
	H	R0442 293 01	R0442 213 01
	N	R0442 294 01	-
15	P	-	R0442 512 01
	H	R0442 593 01	R0442 513 01
	N	R0442 594 01	-
20	P	-	R0442 012 01
	H	R0442 093 01	R0442 013 01
	N	R0442 094 01	-

Take frictional drag of the respective seals into account.

See "Technical Data", section "Friction and seals".

Note on dynamic load capacities and moments (see table)

Determination of the dynamic load capacities and moments is based on a travel life of 100,000 m.

Often only 50,000 m are actually stipulated.

For comparison:

Multiply values C , M_t and M_L from the table by 1.26.

Ordering example 1:

Runner block size 12, accuracy class P, preloaded, standard seals

Ordering data: R0442 212 01

Ordering example 2:

Runner block size 7, accuracy class H, clearance, N seals

Ordering data: R0442 793 01

Ordering example 3:

Runner block size 15, accuracy class H, preloaded, N seals and longitudinal seals, no basic lubrication

Ordering data: R0442 513 40

Ordering example 4:



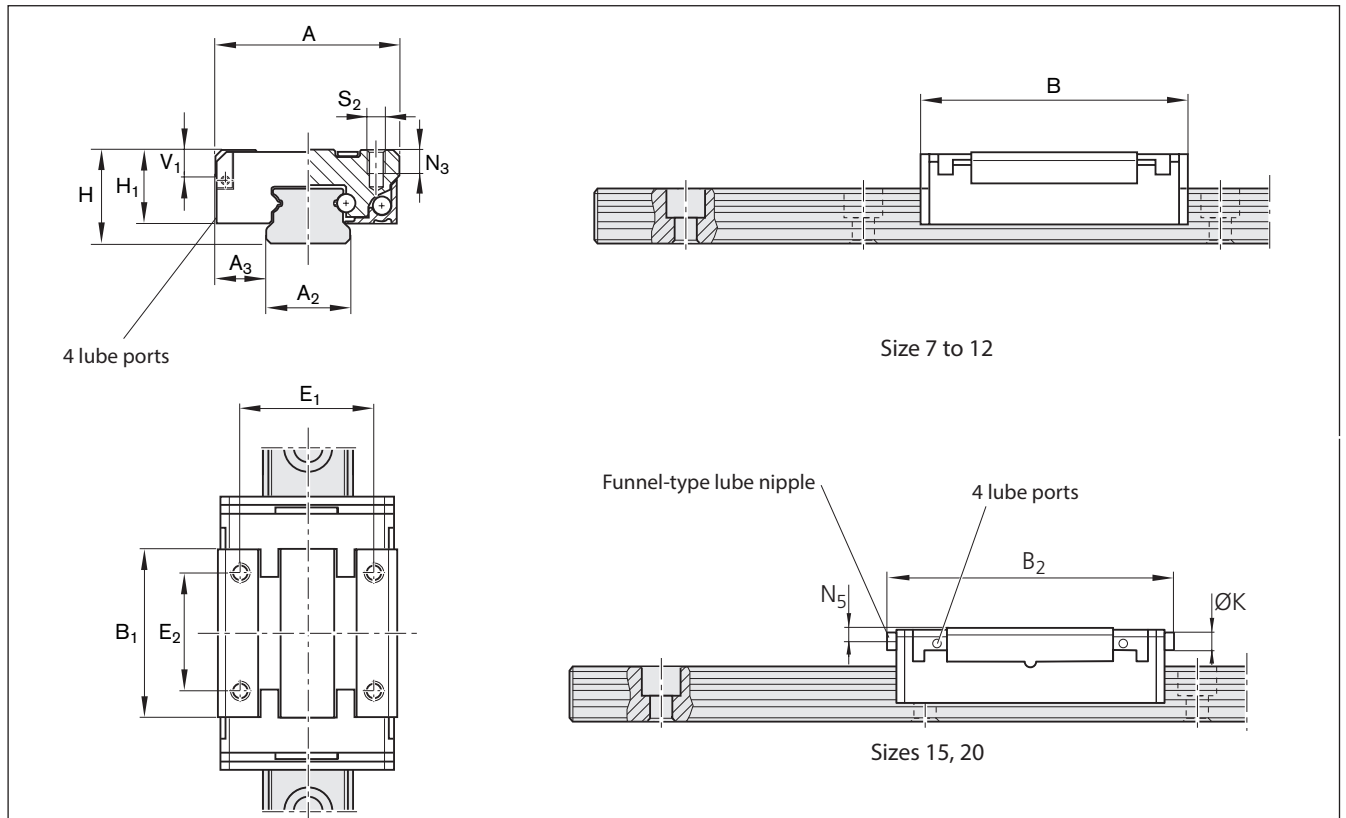

Runner block size 9/M3, accuracy class N, clearance, standard seals, no basic lubrication

Ordering data: R0442 894 41



Size	Dimensions (mm)															
	A	A ₂	A ₃	B	B ₁	B ₂	H	H ₁ ¹⁾	H ₁ ²⁾	V ₁	E ₁	E ₂	K	N ₃	N ₅	S ₂
7	17	7	5.0	24.0	14.9	-	8	6.5	-	2.0	12	8	-	2.5	-	M2
9/M3	20	9	5.5	31.0	20.7	-	10	8.0	-	2.8	15	10	-	3.0	-	M3
12	27	12	7.5	34.8	21.6	-	13	10.0	-	3.3	20	15	-	3.5	-	M3
15	32	15	8.5	43.0	27.2	46	16	12.0	12.65	4.7	25	20	4	4.0	2.1	M3
20	46	20	13.0	66.0	45.1	69	25	17.5	18.15	7.0	38	38	4	6.0	3.1	M4

- 1) Without longitudinal seal
- 2) With longitudinal seal

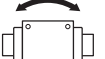
Size	Weight Runner block (g)	Load capacities (N)		Load moments (Nm)			
		 C ¹⁾	 C ₀ ¹⁾	 M _t ²⁾	 M _{to} ²⁾	 M _L ²⁾	 M _{Lo} ²⁾
7	9	860	1400	3.1	5.1	1.9	3.2
9/M3	16	1180	2100	5.4	9.6	3.6	6.4
12	33	2310	3470	13.7	20.6	7.9	11.8
15	47	4200	6260	31.2	46.3	18.3	27.0
20	177	7900	12230	81.4	126.0	51.7	80.0

- 1) Calculated values conforming to DIN 636, Part 2
- 2) Calculated values (based on C, C₀)

SLS – slimline, long, standard height, R0444

All steel parts of the runner block are made of corrosion-resistant, martensitic steel.
The runner blocks are delivered mounted on arbors.

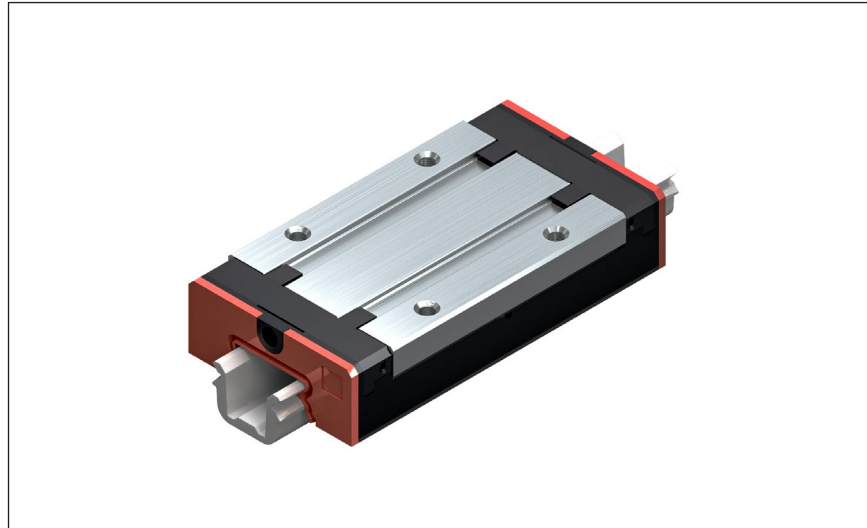

Part numbers for runner blocks

Standard seals: low-friction seals.

Part number: R0444 ... 01

(see table)

Special versions:

Runner blocks are also available:

- with N seals
(excellent wiping action)
Sizes 9/M3, 12 and 15 have additional longitudinal seals for full sealing.
Part number: R0444 ... 00
(otherwise as per table)
- without basic lubrication for individual lubrication.
 - sizes 9/M3, 12 and 15 additionally with N seals and longitudinal seals.
Part number: R0444 ... 40
(otherwise as per table)
 - with low-friction seals
Part number: R0444 ... 41
(otherwise as per table)

Size	Accuracy class	Part numbers for runner blocks	
		Clearance	Preload
7	P	–	R0444 712 01
	H	R0444 793 01	R0444 713 01
	N	R0444 794 01	–
9/M3	P	–	R0444 812 01
	H	R0444 893 01	R0444 813 01
	N	R0444 894 01	–
12	P	–	R0444 212 01
	H	R0444 293 01	R0444 213 01
	N	R0444 294 01	–
15	P	–	R0444 512 01
	H	R0444 593 01	R0444 513 01
	N	R0444 594 01	–

Take frictional drag of the respective seals into account.

See “Technical Data”, section “Friction and seals”.

Note on dynamic load capacities and moments (see table)

Determination of the dynamic load capacities and moments is based on a travel life of 100,000 m.

Often only 50,000 m are actually stipulated.

For comparison:

Multiply values C , M_t and M_L from the table by 1.26.

Ordering example 1:

Runner block size 12, accuracy class P, preloaded, standard seals

Ordering data: R0444 212 01

Ordering example 2:

Runner block size 7, accuracy class H, clearance, N seals

Ordering data: R0444 793 00

Ordering example 3:

Runner block size 15, accuracy class H, preloaded, N seals and longitudinal seals, no basic lubrication

Ordering data: R0444 513 04

Ordering example 4:

Runner block size 9/M3, accuracy class N, clearance, standard seals, no basic lubrication



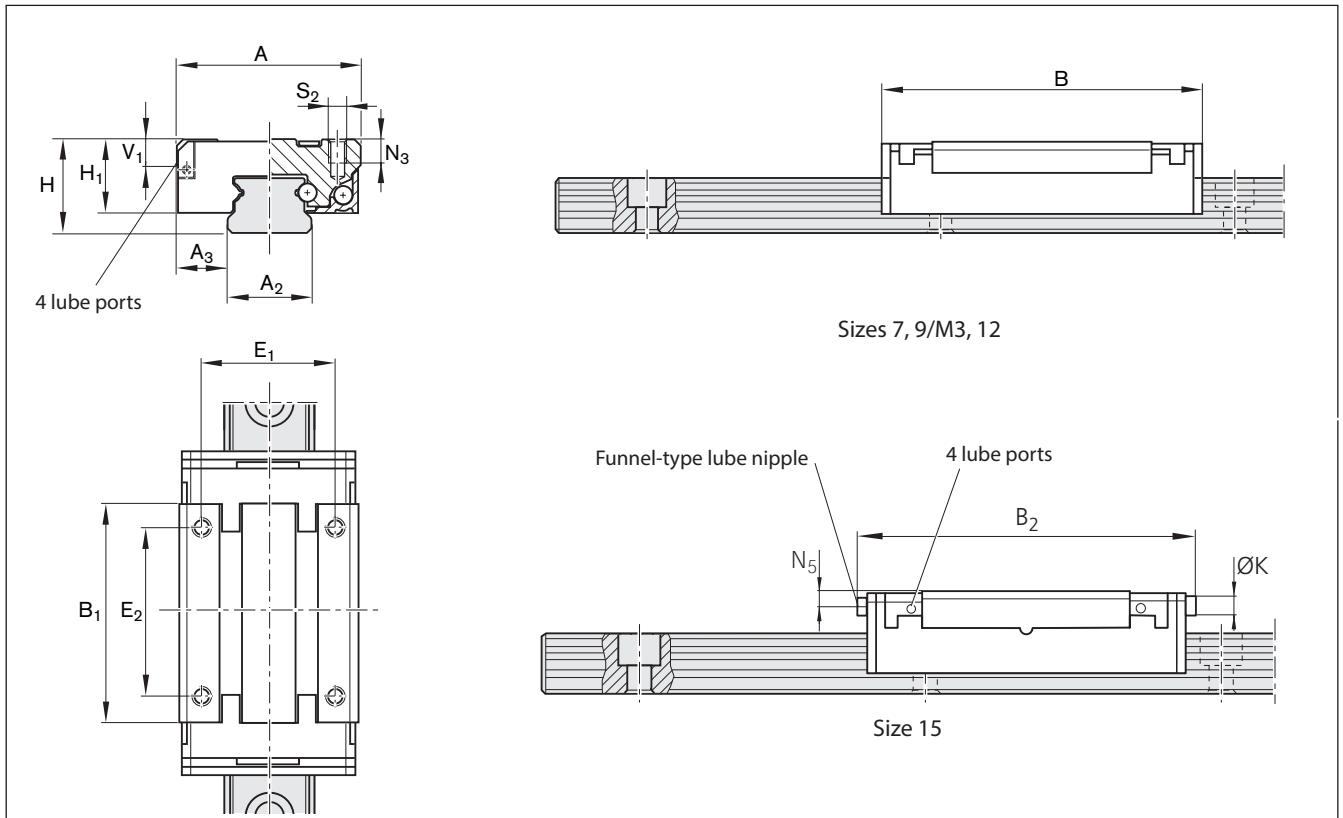

Ordering data: R0444 894 41



Size	Dimensions (mm)																
	A	A ₂	A ₃	B	B ₁	B ₂	H	H ₁ ¹⁾	H ₁ ²⁾	V ₁	E ₁	E ₂	K	N ₃	N ₅	S ₂	
7	17	7	5.0	33.0	24.1	-	8	6.5	-	2.0	12	13	-	2.5	-	M2	
9/M3	20	9	5.5	41.4	31.3	-	10	8.0	8.65	2.8	15	16	-	3.0	-	M3	
12	27	12	7.5	47.5	34.5	-	13	10.0	10.65	3.3	20	20	-	3.5	-	M3	
15	32	15	8.5	60.8	45.0	63.8	16	12.0	12.65	4.7	25	25	4	4.0	2.1	M3	

1) Without longitudinal seal

2) With longitudinal seal

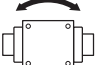
Size	Weight Runner block (g)	Load capacities (N)		Load moments (Nm)			
		 C ¹⁾	 C ₀ ¹⁾	 M _t ²⁾	 M _{t0} ²⁾	 M _L ²⁾	 M _{LO} ²⁾
7	14	1220	2340	4.5	8.5	4.3	8.3
9/M3	26	1570	3150	7.2	14.5	7.0	14.0
12	51	3240	5630	19.3	33.5	16.8	29.2
15	94	5940	10170	44.0	75.3	39.2	67.1

1) Calculated values conforming to DIN 636, Part 2

2) Calculated values (based on C, C₀)

SNS – standard, miniature ball guide rail without / with cover strip R0445

For runner blocks R0442 and R0444.
Guide rails made of corrosion-resistant,
martensitic steel.



Part numbers for guide rails

Size	Accuracy class	Part numbers for guide rails Part number, length L (mm)	
		without cover strip	with cover strip
7	P	R0445 702 31,....	–
	H	R0445 703 31,....	–
	N	R0445 704 31,....	–
9/M3	P	R0445 802 31,....	R0445 862 31,....
	H	R0445 803 31,....	R0445 863 31,....
	N	R0445 804 31,....	R0445 864 31,....
12	P	R0445 202 31,....	R0445 262 31,....
	H	R0445 203 31,....	R0445 263 31,....
	N	R0445 204 31,....	R0445 264 31,....
15 ¹⁾	P	R0445 502 31,....	R0445 562 31,....
	H	R0445 503 31,....	R0445 563 31,....
	N	R0445 504 31,....	R0445 564 31,....
20	P	R0445 002 31,....	R0445 062 31,....
	H	R0445 003 31,....	R0445 063 31,....
	N	R0445 004 31,....	R0445 064 31,....

1) Also available in versions for mounting from below (please ask).

Recommended rail lengths

$$L = n_B \cdot T - 4$$

L = rail length (mm)
T = hole spacing (mm)
n_B = number of holes

Dimensions and weights

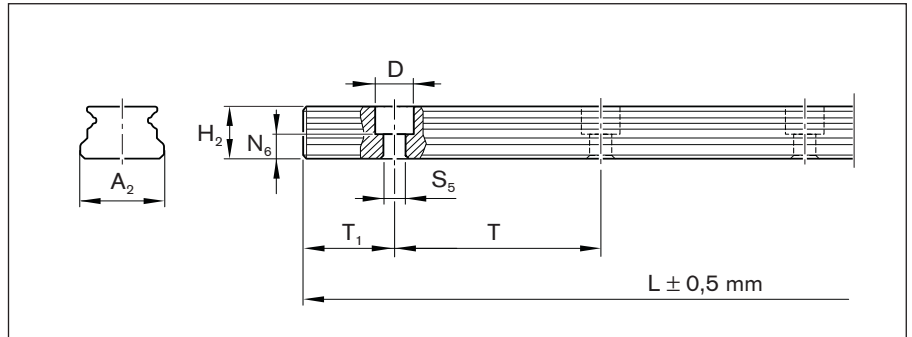

Size	Dimensions (mm)									Weight g/100 mm
	A_2	$H_2^{1)}$	N_6	D	S_5	$T_{1\min}$	$T_{1\max}$	T	$L_{\max}^{2)3)}$	
7	7	4.7	2.2	4.3	2.5	5.0	11.5	15	1000	22
9/M3	9	5.5	2.2	6.0	3.5	6.0	15.5	20	2000	33
12	12	7.8	3.0	6.0	3.5	6.0	20.5	25	2000	61
15	15	9.5	4.7	6.0	3.5	6.0	35.5	40	2000	97
20	20	15.0	6.5	9.5	6.0	6.5	53.5	60	1000	211

1) Dimensions without cover strip

2) For rail lengths longer than L_{\max} factory-made mating sections are joined end-to-end.

3) For special cases one-piece guide rails up to 2000 mm length possible (please ask).

Ordering Examples

☞ If no T_1 is specified by the customer, both ends of the guide rail will be identical. The rail lengths were calculated using the formula for recommended rail lengths.

Ordering example 1

(up to L_{\max}):

Guide rail size 12, accuracy class P, recommended rail length 771 mm ($30 \cdot T$, number of holes $n_B = 31$, T_1 is identical at both ends of the guide rail)

Ordering data: R0445 202 31, 771 mm

Ordering example 2

(up to L_{\max} with cover strip):

Guide rail size 12 with cover strip, accuracy class P, recommended rail length 771 mm ($30 \cdot T$, number of holes $n_B = 31$, T_1 at one end of guide rail = 4.5 mm)

Ordering data:

R0445 262 31, 771 mm, $T_1 = 4.5 \text{ mm}$

(At the other end of the guide rail $T_1 = 16.5 \text{ mm}$ for production reasons.)

Ordering example 3

(composite rail over L_{\max}):

Guide rail size 12, accuracy class N, recommended rail length 1271 mm, 2 sections ($50 \cdot T$, number of holes $n_B = 51$, T_1 is identical at both ends of the composite guide rail)

Ordering data: R0445 204 32, 1271 mm

Number of sections $\left. \begin{array}{l} \text{---} \\ \text{---} \end{array} \right\}$

Ordering example 4

(one-piece over L_{\max}):

Guide rail size 12, accuracy class P, recommended rail length 1771 mm ($70 \cdot T$, number of holes $n_B = 71$, T_1 is identical at both ends of the guide rail)

Ordering data: R0445 202 31, 1771 mm

Note on adjacent structures

Permissible mounting hole tolerances for adjacent structures with one-piece guide rails.

Size	Hole position tolerance (mm)
7 - 20	$\varnothing 0.2$

BNS – wide, normal, standard height, R0443

All steel parts of the runner block are made of corrosion-resistant, martensitic steel.
The runner blocks are delivered mounted on arbors.

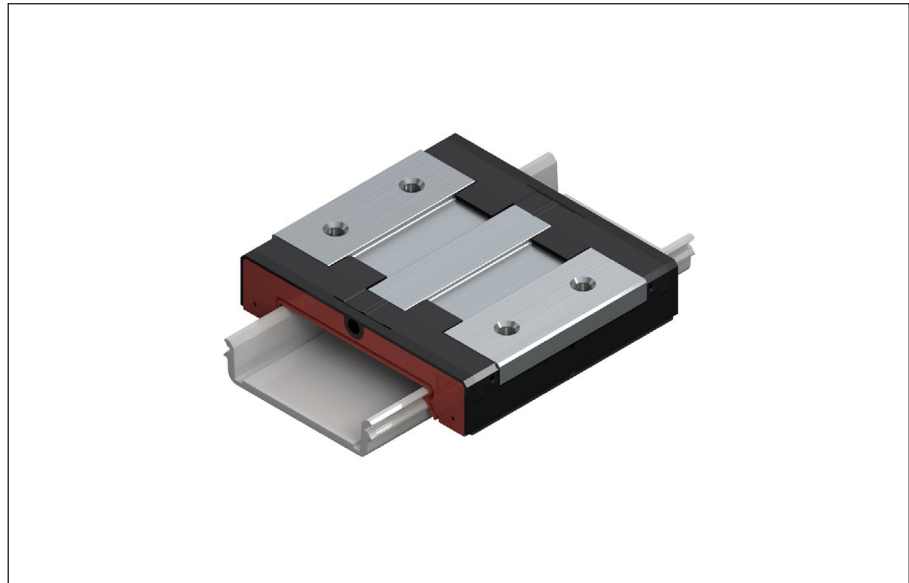

Part numbers for runner blocks

Standard seals: low-friction seals.

Part number: R0443 ... 01
(see table)

Special versions:

Runner blocks are also available:

- with N seals (excellent wiping action) and longitudinal seals for full sealing.
Part number: R0443 ... 00
(otherwise as per table)
- without basic lubrication for individual lubrication.
 - with N seals and longitudinal seals
Part number: R0443 ... 40
(otherwise as per table)
 - with low-friction seals
Part number: R0443 ... 41
(otherwise as per table)

Size	Accuracy class	Part numbers for runner blocks	
		Clearance	Preload
9/M3	P	–	R0443 812 01
	H	R0443 893 01	R0443 813 01
	N	R0443 894 01	–
12	P	–	R0443 212 01
	H	R0443 293 01	R0443 213 01
	N	R0443 294 01	–
15	P	–	R0443 512 01
	H	R0443 593 01	R0443 513 01
	N	R0443 594 01	–

Take frictional drag of the respective seals into account.

See “Technical Data”, section “Friction and seals”.

Note on dynamic load capacities and moments (see table)

Determination of the dynamic load capacities and moments is based on a travel life of 100,000 m.

Often only 50,000 m are actually stipulated.

For comparison:

Multiply values C , M_t and M_l from the table by 1.26.

Ordering example 1:

Runner block size 12, accuracy class P, preloaded, standard seals

Ordering data: R0443 212 01

Ordering example 2:

Runner block size 12, accuracy class H, clearance, N seals

Ordering data: R0443 293 00

Ordering example 3:

Runner block size 15, accuracy class H, preloaded, N seals and longitudinal seals, no basic lubrication

Ordering data: R0443 513 40

Ordering example 4:

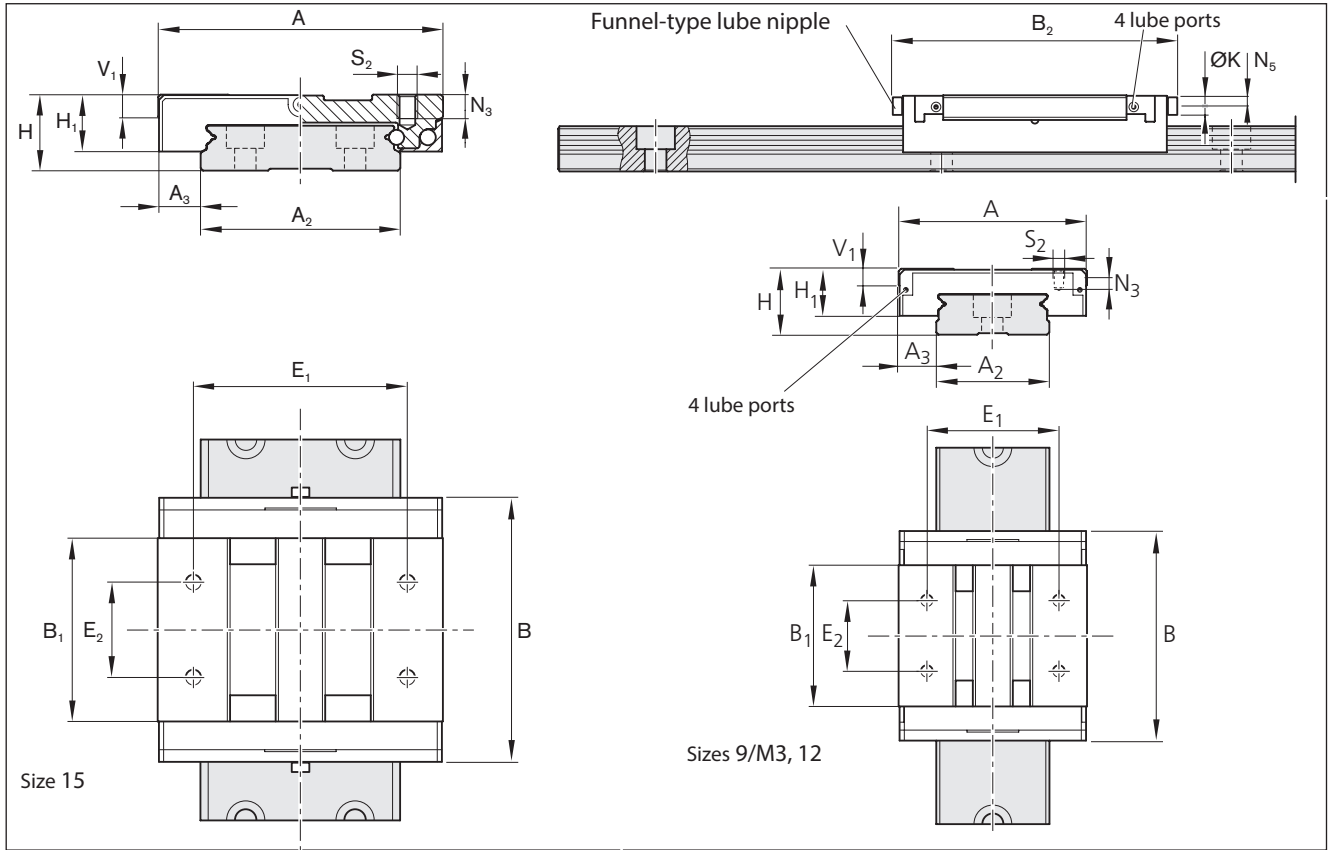

Runner block size 9/M3, accuracy class N, clearance, standard seals, no basic lubrication

Ordering data: R0443 894 41



Size	Dimensions (mm)															
	A	A ₂	A ₃	B	B ₁	B ₂	H	H ₁ ¹⁾	H ₁ ²⁾	V ₁	E ₁	E ₂	K	N ₃	N ₅	S ₂
9/M3	30	18	6.0	39.0	31.3	–	12	9.0	9.65	2.8	21	12	–	3.2	–	M3
12	40	24	8.0	44.5	34.5	–	14	10.0	10.65	3.3	28	15	–	4.0	–	M3
15	60	42	9.0	55.5	38.6	58.5	16	12.0	12.65	4.7	45	20	4	4.5	2.1	M4

- 1) Without longitudinal seal
- 2) With longitudinal seal

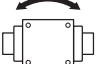
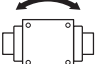
Size	Weight Runner block (g)	Load capacities (N)		Load moments (Nm)			
		 C ¹⁾	C ₀ ¹⁾	 M _t ²⁾	 M _{t0} ²⁾	 M _L ²⁾	 M _{L0} ²⁾
9/M3	26	1920	3330	15.9	27.6	7.4	12.9
12	51	3200	5340	37.9	63.2	14.3	23.9
15	110	5285	8610	107.0	174.0	30.0	49.0

- 1) Calculated values conforming to DIN 636, Part 2
- 2) Calculated values (based on C, C₀)

BLS – wide, long, standard height, R0441

All steel parts of the runner block are made of corrosion-resistant, martensitic steel.
The runner blocks are delivered mounted on arbors.

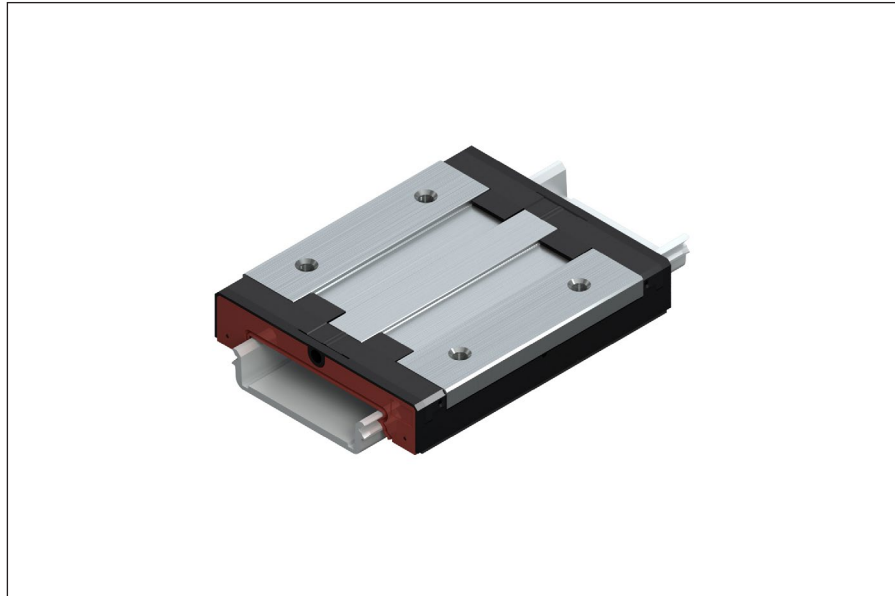

Part numbers for runner blocks

Standard seals: low-friction seals.

Part number: R0441 ... 01
(see table)

Special versions:

Runner blocks are also available:

- with N seals (excellent wiping action) and longitudinal seals for full sealing.
Part number: R0441 ... 00
(otherwise as per table)
- without basic lubrication for individual lubrication.
 - with N seals and longitudinal seals
Part number: R0441 ... 40
(otherwise as per table)
 - with low-friction seals
Part number: R0441 ... 41
(otherwise as per table)

Size	Accuracy class	Part numbers for runner blocks	
		Clearance	Preload
9/M3	P	–	R0441 812 01
	H	R0441 893 01	R0441 813 01
	N	R0441 894 01	–
12	P	–	R0441 212 01
	H	R0441 293 01	R0441 213 01
	N	R0441 294 01	–
15	P	–	R0441 512 01
	H	R0441 593 01	R0441 513 01
	N	R0441 594 01	–

Take frictional drag of the respective seals into account.
See “Technical Data”, section “Friction and seals”.

Note on dynamic load capacities and moments (see table)

Determination of the dynamic load capacities and moments is based on a travel life of 100,000 m.

Often only 50,000 m are actually stipulated.

For comparison:

Multiply values C , M_t and M_l from the table by 1.26.

Ordering example 1:

Runner block size 12, accuracy class P, preloaded, standard seals

Ordering data: R0441 212 01

Ordering example 2:

Runner block size 12, accuracy class H, clearance, N seals

Ordering data: R0441 293 00

Ordering example 3:

Runner block size 15, accuracy class H, preloaded, N seals and longitudinal seals, no basic lubrication

Ordering data: R0441 513 40

Ordering example 4:



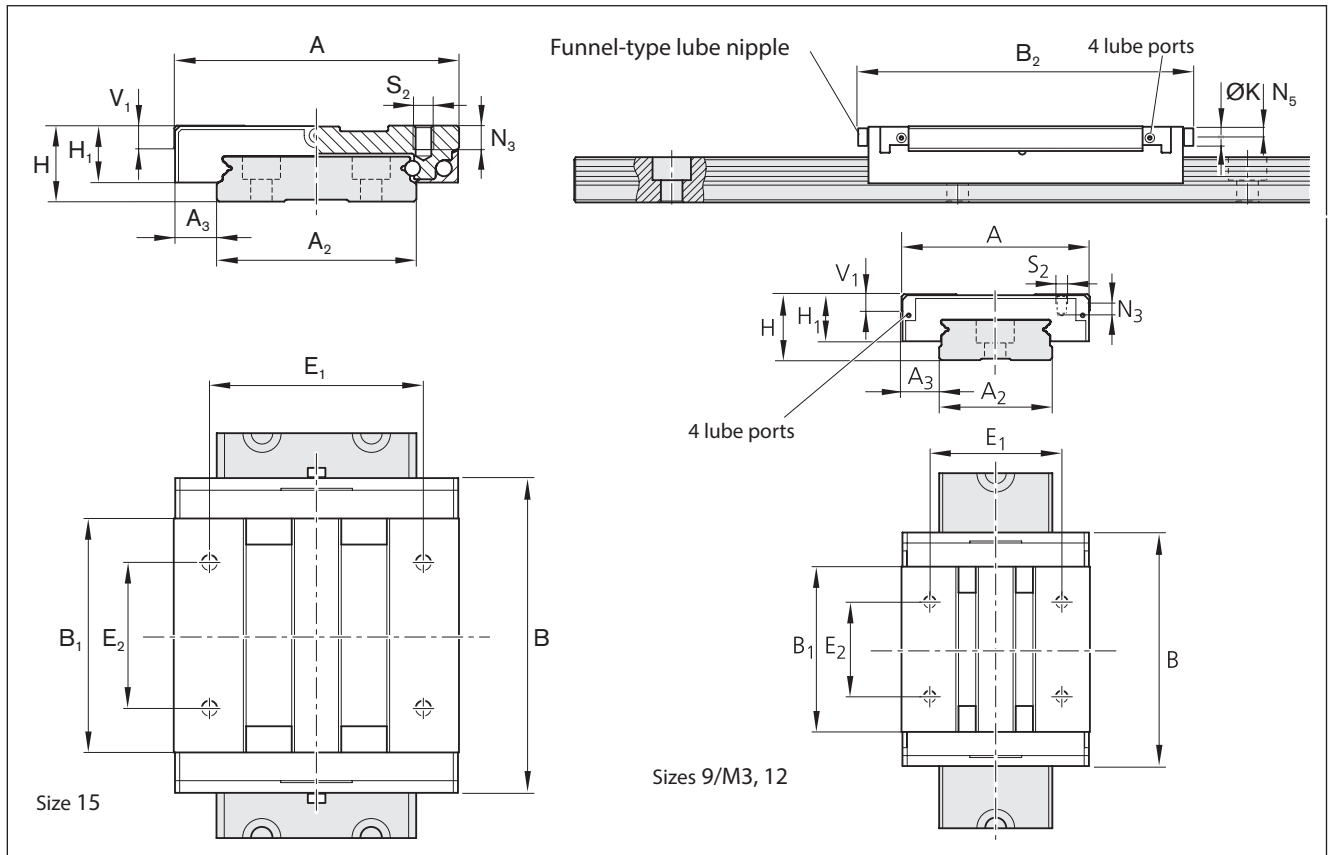

Runner block size 9/M3, accuracy class N, clearance, standard seals, no basic lubrication

Ordering data: R0441 894 41



Size	Dimensions (mm)																
	A	A ₂	A ₃	B	B ₁	B ₂	H	H ₁ ¹⁾	H ₁ ²⁾	V ₁	E ₁	E ₂	K	N ₃	N ₅	S ₂	
9/M3	30	18	6.0	51.0	38.0	–	12	9.0	9.65	2.8	23	24	–	3.2	–	M3	
12	40	24	8.0	59.5	45.0	–	14	10.0	10.65	3.3	28	28	–	4.0	–	M3	
15	60	42	9.0	74.5	57.6	77.5	16	12.0	12.65	4.7	45	35	4	4.5	2.1	M4	

- 1) Without longitudinal seal
- 2) With longitudinal seal

Size	Weight Runner block (g)	Load capacities (N)			Load moments (Nm)					
			C ¹⁾	C ₀ ¹⁾		M _t ²⁾		M _{t0} ²⁾		M _L ²⁾
9/M3	41	2825	5590	23.5	46.4	15.8	31.2			
12	76	4340	8250	51.4	97.7	28.7	54.6			
15	170	7460	14085	151.0	285.2	66.1	125.0			

- 1) Calculated values conforming to DIN 636, Part 2
- 2) Calculated values (based on C, C₀)

BNS – wide, miniature ball guide rail without / with cover strip R0455

For runner blocks R0443 and R0441
 Mounting hole pattern, size 9/M3, 12:
 – single row
 Mounting hole pattern, size 15:
 – double row
 Guide rails made of corrosion-resistant, martensitic steel.



Part numbers for guide rails

Size	Accuracy class	Part numbers for wide guide rails	
		Part number, length L (mm) without cover strip	with cover strip
9/M3	P	R0455 802 31,....	R0455 862 31,....
	H	R0455 803 31,....	R0455 863 31,....
	N	R0455 804 31,....	R0455 864 31,....
12	P	R0455 202 31,....	R0455 262 31,....
	H	R0455 203 31,....	R0455 263 31,....
	N	R0455 204 31,....	R0455 264 31,....
15	P	R0455 502 31,....	R0455 562 31,....
	H	R0455 503 31,....	R0455 563 31,....
	N	R0455 504 31,....	R0455 564 31,....

Recommended rail lengths

$$L = n_B \cdot T - 4$$

L = rail length (mm)
 T = hole spacing (mm)
 n_B = number of holes per row

Ordering Examples

☞ If no T_1 is specified by the customer, both ends of the guide rail will be identical. The rail lengths were calculated using the formula for recommended rail lengths.

Ordering example 1

(up to L_{max}):
 Guide rail size 12, accuracy class P, recommended rail length 836 mm ($20 \cdot T$, number of holes $n_B = 21$, T_1 is identical at both ends of the guide rail)
 Ordering data: R0455 202 31, 836 mm

Ordering example 2

(up to L_{max} with cover strip):
 Guide rail size 9/M3, accuracy class H, recommended rail length 926 mm ($30 \cdot T$, number of holes $n_B = 31$, T_1 at one end of guide rail = 4.5 mm)
 Ordering data:
 R0455 863 31, 926 mm, $T_1 = 4.5$ mm
 (At the other end of the guide rail $T_1 = 21.5$ mm for production reasons)

Ordering example 3

(composite rail over L_{max}):
 Guide rail size 15, accuracy class N, recommended rail length 1436 mm, 2 sections ($35 \cdot T$, number of holes $n_B = 36$ per row, T_1 is identical at both ends of the composite guide rail)
 Ordering data: R0455 504 32, 1436 mm

Number of sections

Ordering example 4

(one-piece over L_{max}):
 Guide rail size 12, accuracy class P, recommended rail length 1636 mm ($40 \cdot T$, number of holes $n_B = 41$, T_1 is identical at both ends of the guide rail)
 Ordering data: R0455 202 31, 1636 mm

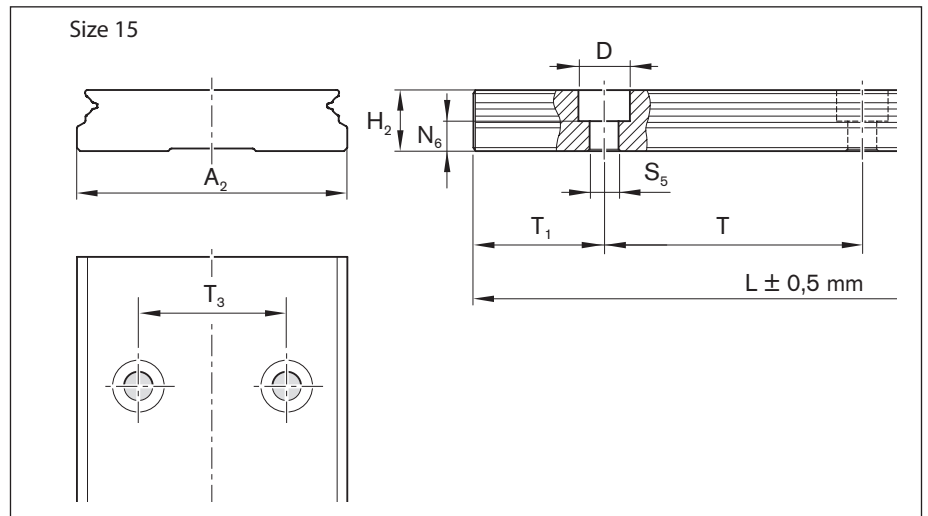
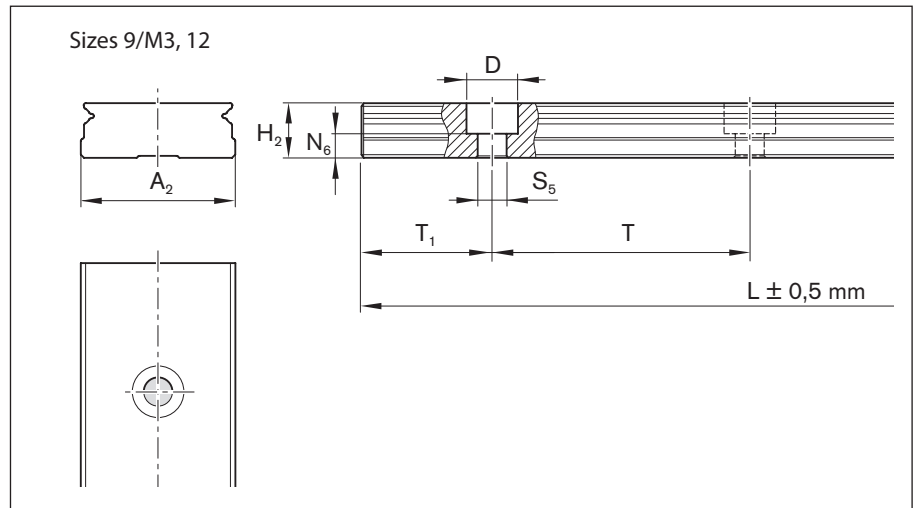
Dimensions and weights

Size	Dimensions (mm)										Weight (g/100 mm)
	A ₂	H ₂ ¹⁾	N ₆	D	S ₅	T _{1min}	T _{1max}	T	T ₃	L _{max} ²⁾³⁾	
9/M3	18	7.5	2.7	6.0	3.5	6.0	25.5	30	–	1000	92
12	24	8.5	3.7	8.0	4.5	6.0	34.5	40	–	1000	145
15	42	9.5	4.7	8.0	4.5	6.0	34.5	40	23	2000	286

1) Dimensions without cover strip

2) For rail lengths longer than L_{max} factory-made mating sections are joined end-to-end.

3) For special cases one-piece guide rails up to 2000 mm length possible (please ask).

Note on adjacent structures

Permissible mounting hole tolerances for adjacent structures with one-piece guide rails.

Size	Hole position tolerance (mm)
9/M3 - 15	∅ 0.2

Accessories

Loose cover strip

For initial installation,
storage and replacement

Note

A suitable cover strip with
snap fit or with sliding fit is
available for each ball guide
rail SNS/BNS.

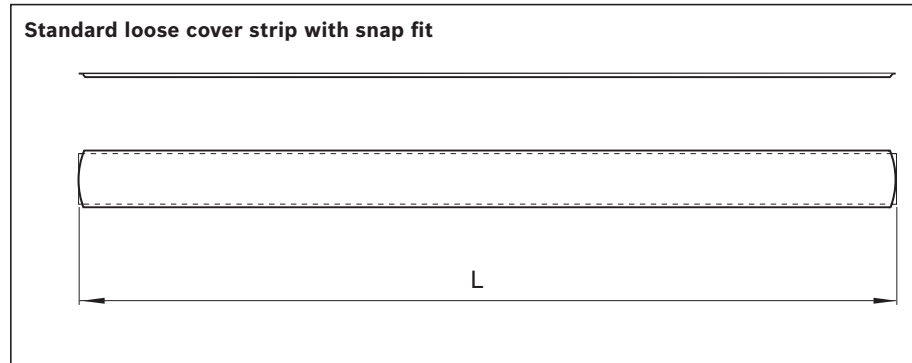

Ordering example 1 (standard cover strip with snap fit)

- ▶ Ball guide rail SNS
- ▶ Size 15
- ▶ Rail length
L = 1636 mm

Part number:

R0419 530 00, 1636 mm

Size	Standard loose cover strip with snap fit Part number, rail length L (mm)	Weight (g/m)
9/M3	R0419 830 00, ...	9
12	R0419 230 00, ...	10
15	R0419 530 00, ...	12
20	R0419 030 00, ...	17
9/M3 wide	R0419 830 50, ...	14
12 wide	R0419 230 50, ...	20
15 wide	R0419 530 50, ...	32

Start-up and maintenance

Start-up

Initial lubrication of runner blocks is necessary before miniature ball rail systems are put into service!

Runner blocks are available:

- prelubricated with a lithium soap grease, consistency class NLGI 00, Dynalub 520
- without initial lubrication for individual grease or oil lubrication.

Initial lubrication with grease

We recommend a grease lubricant per DIN 51825, class KP00K.

A grease of this type, Dynalub 520, is available in the following versions:

- Maintenance kit with 5 ml dispensing unit, part number R0419 090 01
- 400 g cartridge for use in grease guns, part number R3416 043 00

Note:

- Grease the runner block as per table.
- Move the runner block in the direction of the lube port used to distribute the grease evenly.
- Make sure there is a visible film of grease on the guide rail.

Initial lubrication with oil

We recommend the use of oils meeting the minimum requirements for CLP lubricant oils (DIN 51517, Part 3) or HLP hydraulic oils (DIN 51524, Part 2). The oil must have a viscosity of 100 mm²/s at 40 °C.

- Follow the manufacturer's instructions.
- It is essential to check that the lubricant will reach all rolling elements in the installed condition (orientation).
- Apply oil until excess emerges.

 Add the entire oil quantity in one go!

Maintenance

The maintenance intervals depend on the application and the ambient conditions.

Under normal conditions no in-service lubrication is required.

Cleaning

Dirt can settle and encrust on the guide rails, especially when these are not enclosed. This dirt must be removed to protect the seals.

- Always run a cleaning cycle before shutting down the machine.

In-service lubrication

Initial lubrication (long-term lubrication) is sufficient for 5,000 km travel where:

- $F < 0.1 \text{ C}$
- $v_m = 0.65 \text{ m/s}$
- 90 mm stroke
- low-friction seals
- For in-service lubrication with grease or oil, follow instructions as for initial lubrication.

 The in-service lubrication intervals depend on ambient conditions, loading and type of load!

Ambient conditions include: swarf, metallic and other abrasion, solvents and temperature. Load types include vibrations, impacts and tilting.

 The service conditions are unknown to the manufacturer. Users can only determine the in-service lubrication intervals with certainty by conducting in-house tests or by careful observation.

 Do not allow guide rails or runner blocks to come into contact with water-based metalworking fluids!

Maintenance kit

A special syringe is used to apply lubricant to the lube ports at the sides or end faces of the runner block.

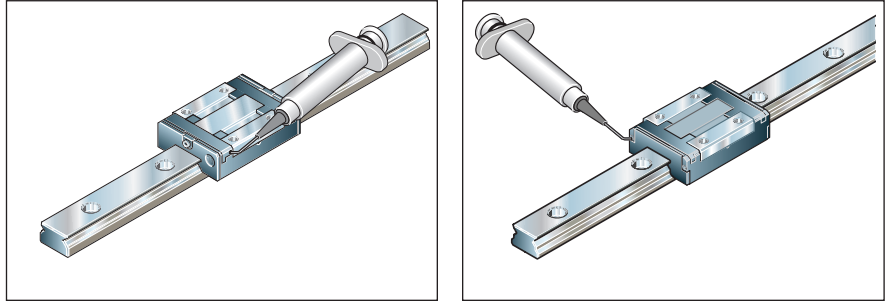

Article	Part number
Syringe filled	R0419 090 01
Syringe unfilled	R0419 090 02

If the funnel-type lube nipples on the runner block end faces are preferred, use a grease gun instead.

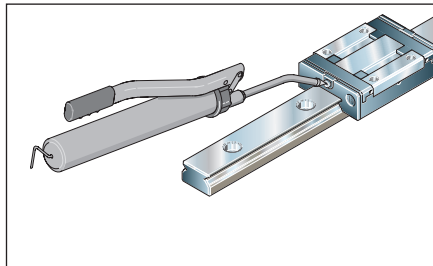

Short stroke
(stroke < 2 runner block lengths)

See "Lubrication quantities and methods" for the method to be used for short-stroke applications.

For strokes < 0.5 runner block length, slide the runner block over 2 complete runner block lengths per lubrication cycle. If this is not possible, please consult us.

Lubrication quantities and methods

The lubrication method depends on the size, as given in the table:

Size	Lubrication by method 1	method 2
Standard runner block R0442		
7		✓
9/M3		✓
12		✓
15		
20		✓
Long runner block R0444		
7		✓
9/M3		✓
12		✓
15		
Wide runner block R0443; wide, long R0441		
9/M3		✓
12		✓
15		✓

Method 1

Apply lubricant through the lube ports on the end face.

Size	Initial lubrication with grease	
	Partial amount per side (L/R)* (cm ³)	Total amount (L+R)* (cm ³)
Standard runner block R0442		
7	0.025	0.05
9/M3	0.030	0.06
12	0.075	0.15
Long runner block R0444		
7	0.04	0.08
9/M3	0.045	0.09
12	0.12	0.24
Wide runner block R0443		
9/M3	0.040	0.08
12	0.075	0.15
Wide, long runner block R0441		
9/M3	0.060	0.12
12	0.11	0.22

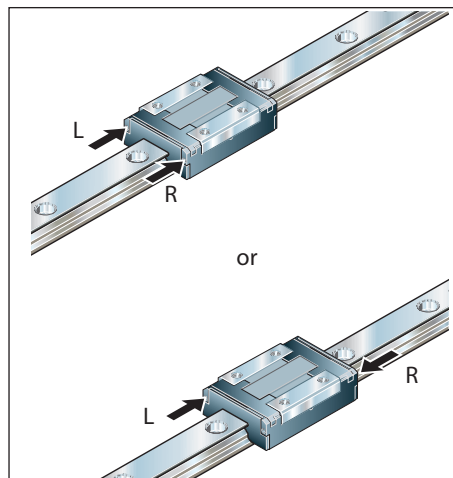

For short stroke applications, apply the partial amount per side as given in the table to each end-face lube port.

* (L = left, R = right)

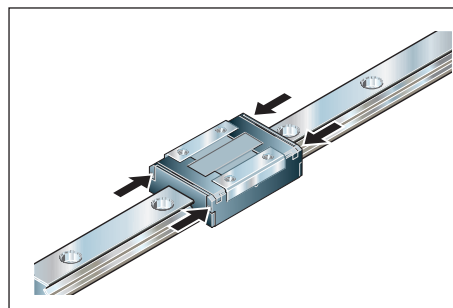

Method 2

Apply lubricant through the lube ports at the sides (partial amount per side) or the lube nipple on the end face (total amount).

Size	Initial lubrication with grease	
	Partial amount per side (L/R) (cm ³)	Total amount via end face (cm ³)
Standard runner block R0442		
15	0.06	0.12
20	0.09	0.18
Long runner block R0444		
15	0.10	0.20
Wide runner block R0443		
15 B	0.09	0.18
Wide, long runner block R0441		
15	0.13	0.26

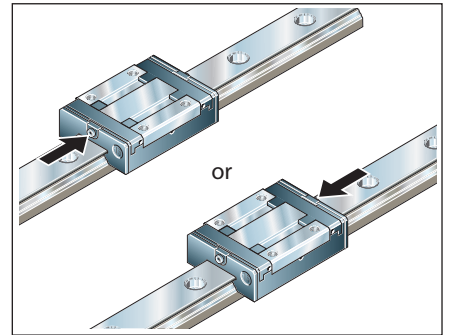
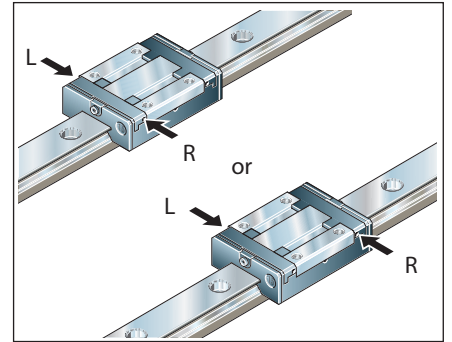

For short-stroke applications, apply either the total amount as per table to each end-face lube nipple, or the partial amount per side as given in the table to each side lube port.

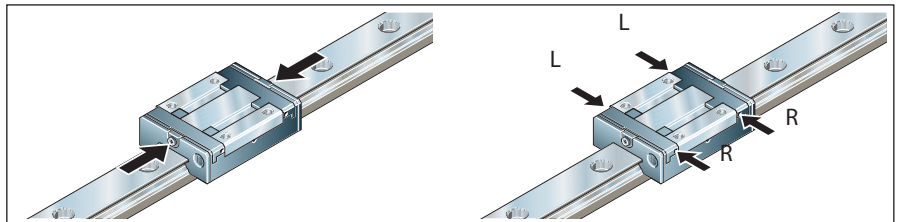

Further informations

Homepage Bosch Rexroth Linear Motion Technology

<https://www.boschrexroth.com/web/a74aa994-0afe-4a3b-9e3f-3e615572d31a>

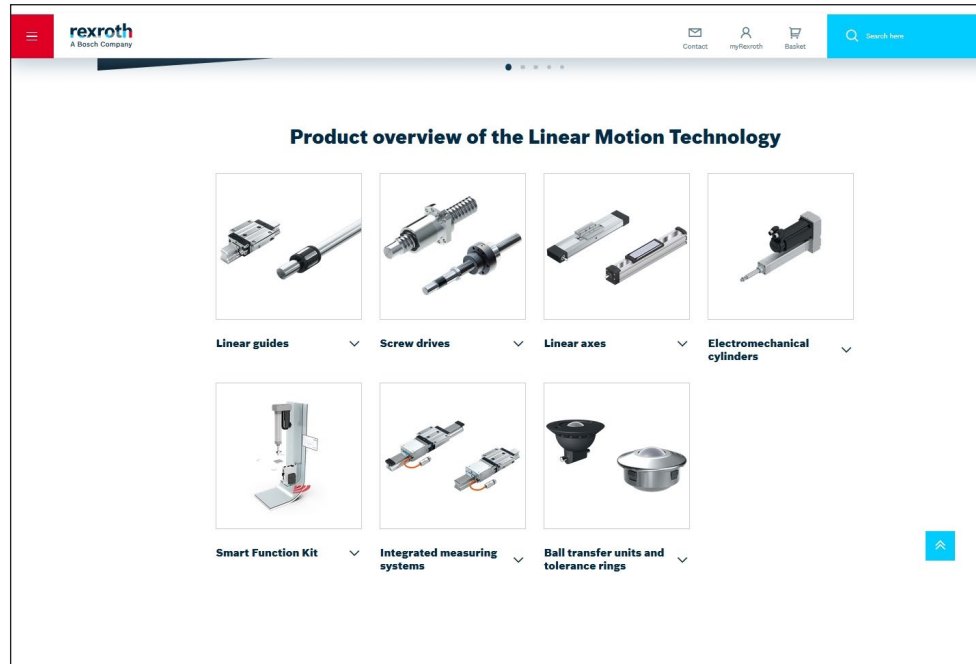

The screenshot shows the 'Product overview of the Linear Motion Technology' page on the Bosch Rexroth website. The page features a navigation bar with the Rexroth logo, contact information, and a search bar. Below the navigation bar, the main heading is 'Product overview of the Linear Motion Technology'. The content is organized into two rows of product categories, each with a representative image and a dropdown arrow:

- Linear guides
- Screw drives
- Linear axes
- Electromechanical cylinders
- Smart Function Kit
- Integrated measuring systems
- Ball transfer units and tolerance rings

Configurator and tools

<https://www.boschrexroth.com/de/de/produkte/konfiguratoren-und-tools/>

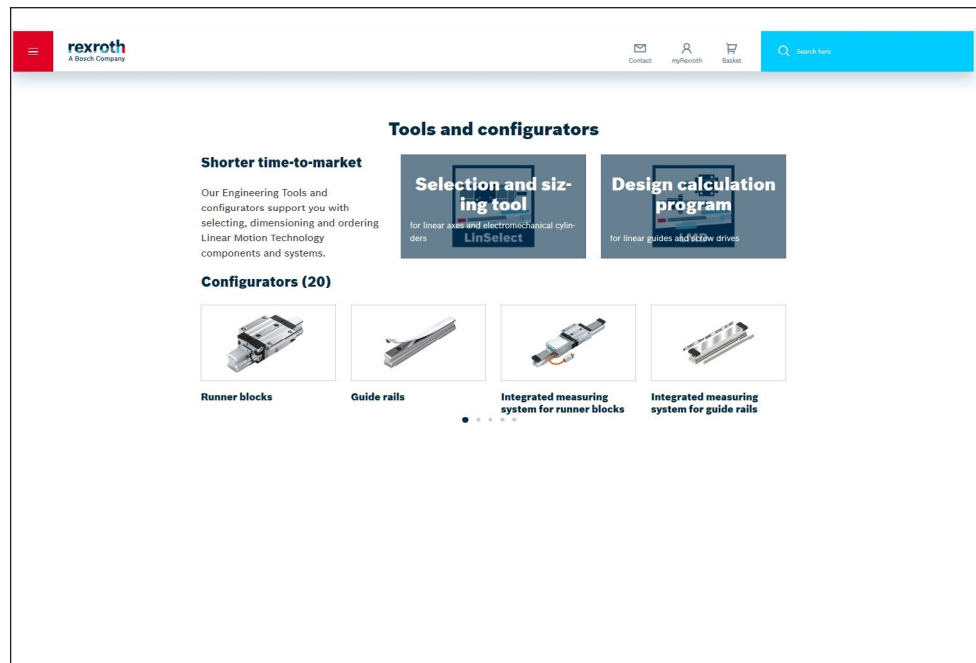

The screenshot shows the 'Tools and configurators' page on the Bosch Rexroth website. The page features a navigation bar with the Rexroth logo, contact information, and a search bar. Below the navigation bar, the main heading is 'Tools and configurators'. The content is organized into several sections:

- Shorter time-to-market**: A text block stating that Engineering Tools and configurators support users with selecting, dimensioning, and ordering Linear Motion Technology components and systems.
- Selection and sizing tool**: A graphic for 'LinSelect' for linear axes and electromechanical cylinders.
- Design calculation program**: A graphic for design calculation for linear guides and screw drives.
- Configurators (20)**: A section with four product images and labels: Runner blocks, Guide rails, Integrated measuring system for runner blocks, and Integrated measuring system for guide rails.

How-to: Linear Motion Technology

<https://www.youtube.com/playlist?list=PLRO3LeFQeLyMF6evW4E7kR93JHzpJIV4r>

A screenshot of a YouTube playlist page. The page title is "How-to: Linear Motion Technology" by the channel "Bosch Rexroth". The main video thumbnail shows a blue banner with the text "Rexroth IMScompact Mounting a system". Below the main video, there is a list of 7 videos in the playlist, each with a thumbnail and a duration. The videos are:

- [EN] Rexroth IMScompact - Mounting a system (3:41)
- Roller Rail System RSHP - Mounting wedge profile retaining strip (2:48)
- Roller Rail System RSHP - Mounting composite guide rail (3:30)
- Roller Rail System RSHP - Removing the snap fit cover strip with pre-mounted superstructure (1:34)
- Roller Rail System RSHP - Open guide rail packaging (0:51)
- Roller Rail System RSHP - Mounting and aligning parallel guide rails (2:45)
- Rexroth Function Module (FMB) - Motor mounting with flange and gearbox (9:24)

The left sidebar shows the YouTube navigation menu with options like Start, Trends, Abos, Mediathek, and Verlauf. The bottom left corner of the screenshot shows "DAS BESTE AUF YOUTUBE" with categories like Sport, Gaming, Filme & Shows, Nachrichten, Live, Lehrinhalte, and 360°-Video.

Further informations

Service

<https://www.boschrexroth.com/de/de/produkte/produktgruppen/lineartechnik/#support>

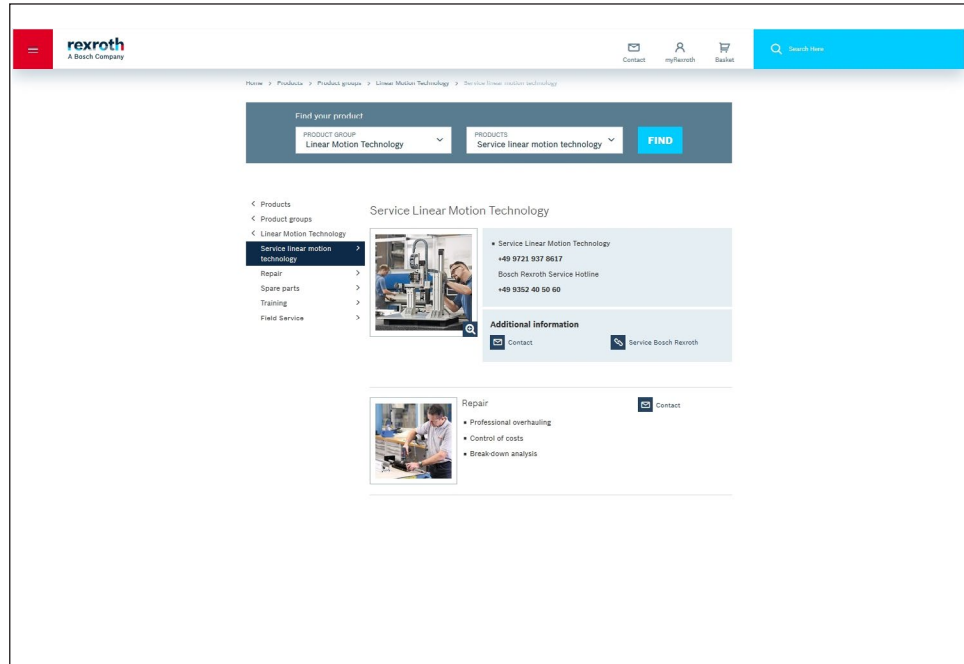

Trainings

<https://www.boschrexroth.com/de/de/academy/>

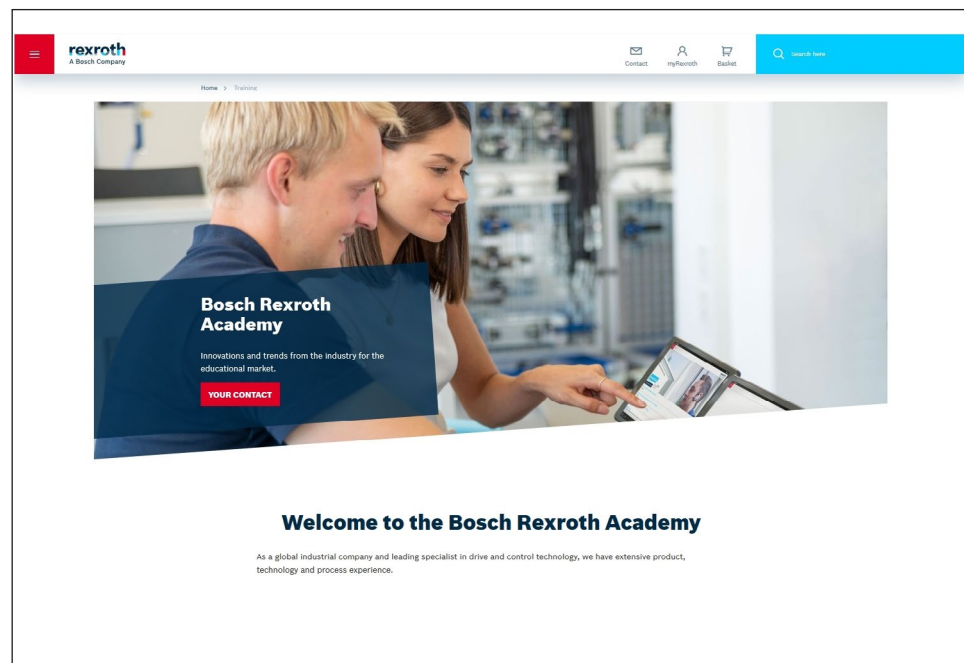

Bosch Rexroth AG

Ernst-Sachs-Straße 100
97424 Schweinfurt, Germany
Tel. +49 9721 937-0
Fax +49 9721 937-275
www.boschrexroth.com

Find your local contact person here:

www.boschrexroth.com/contact

