



AUTOMATION

CILINDRI COMPATTI ISO21287
ISO21287 COMPACT CYLINDERS

SERIE

CA



MADE IN ITALY



VERSIONI - VERSIONS

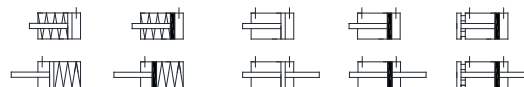

Materiali - Materials	
Testate - Covers	Alluminio pressofuso verniciato Painted die-casted aluminum
Tubo - Tube	Alluminio anodizzato Anodized aluminum
Stelo - Piston rod	Acciaio INOX AISI303 Stainless steel AISI303
Pistone - Piston	Alluminio Aluminum
Guarnizioni - Seals	PU / NBR
Boccola guida Guiding bush	Acciaio + PTFE Steel + PTFE

Informazioni tecniche - Technical features	
Fluido - Fluid	Aria compressa filtrata lubrificata e non Filtered and lubricated or not compressed air
Temp impiego Working Temp.	-20°C +80°C con aria secca / w dry air
Pressione MAX MAX pressure	10 bar

CHIAVE DI CODIFICA - KEY CODE

Base		Versioni - Versions						Ø	Corsa - Stroke	
CA	SA	Semplice effetto molla anteriore Single acting front spring	0	Standard	M	Magnetico Magnetic	M	Filetto stelo maschio Male piston rod thread	Ø20	0005
		Semplice effetto molla posteriore Single acting rear spring		Passante Through rod		Non magnetico Not magnetic		Filetto stelo femmina Female piston rod thread		
	SP	Semplice effetto molla anteriore Single acting front spring	1	Standard	N	Magnetico Magnetic	F	Filetto stelo maschio Male piston rod thread
		Semplice effetto molla posteriore Single acting rear spring		Passante Through rod		Non magnetico Not magnetic		Filetto stelo femmina Female piston rod thread		
	DE	Doppio effetto Double acting						100	500	

CODICE ESEMPIO - SAMPLE CODE

CA	DE	0	M	F	050	0100	+	varianti	variants
----	----	---	---	---	-----	------	---	----------	----------

VARIANTI - VARIANTS

Guarnizioni Seals		Versione Version	Materiale stelo Piston rod material		Filetto stelo speciale Special piston rod thread	Prolunga stelo Extended piston rod		Atex	
HR	Guarnizione stelo Viton Viton Rod seal	E	Antirotazione Not rotating	X	AISI316	Su richiesta On request	PXXX	xxx = mm	T
	Tutto Viton All Viton								

CORSE STANDARD - STANDARD STROKES

Ø	5	10	15	20	25	30	40	50	60
20	XY	XY	XY	XY	XY	Y	Y	Y	Y
25	XY	XY	XY	XY	XY	Y	Y	Y	Y
32	XY	XY	XY	XY	XY	Y	Y	Y	Y
40	XY	XY	XY	XY	XY	Y	Y	Y	Y
50	XY	XY	XY	XY	XY	Y	Y	Y	Y
63	XY	XY	XY	XY	XY	Y	Y	Y	Y
80	XY	XY	XY	XY	XY	Y	Y	Y	Y
100	XY	XY	XY	XY	XY	Y	Y	Y	Y

X= Cilindro semplice effetto - Single acting cylinder

Y= Cilindro doppio effetto - Double acting cylinder

FORZE TEORICHE - THEORETICAL FORCES

Forze teoriche molle - Theoretical spring forces (N)		
Ø	Corsa / Stroke 25	
	F1	F2
20	10	25
25	16	33
32	30	50
40	40	55
50	40	65
63	51	77
80	90	115
100	120	160

Forze teoriche a 6 bar Theoretical forces at 6 bar		
Ø	Forza di spinta (N) - Thrust force (N)	Forza in trazione (N) - Traction force (N)
	20	188
25	294	247
32	482	414
40	754	633
50	1178	989
63	1869	1681
80	3014	2720
100	4710	4416

SEMPLICE EFFETTO MOLLA ANTERIORE - SINGLE ACTING FRONT SPRING

CASA0N(M/F) - CASA0M(M/F)

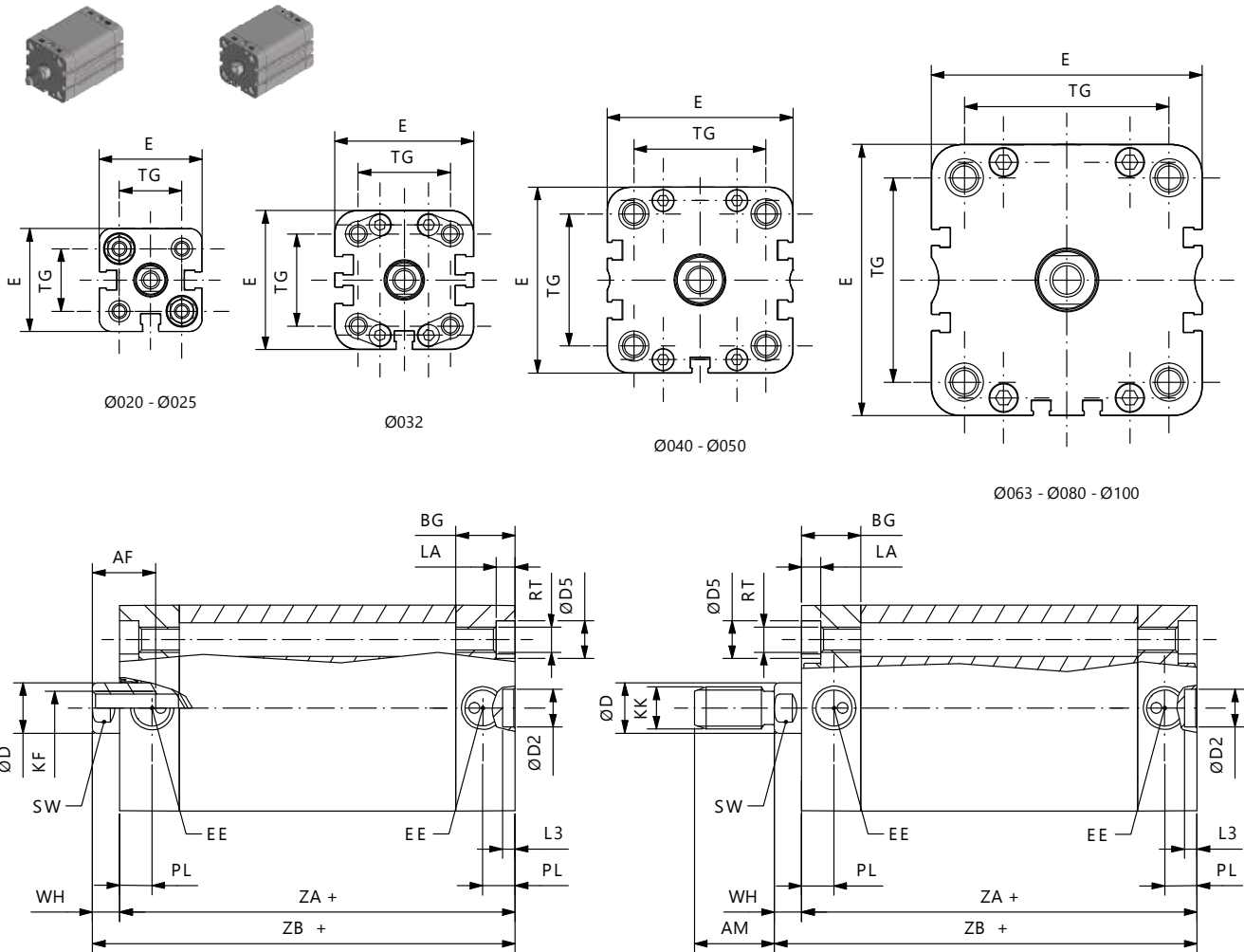

Ø	E	ØD2	RT	ØD5	KF	ØD	EE	PL	BG	TG	SW	L3	AF	WH	ZA +	AM	KK	ZB	LA
20	36	9	M5	7,5	M6	10	M5	7,5	11,8	22	9	3	10	6	37	16	M8X1,25	43	4,5
25	40	9	M5	7,5	M6	10	M5	7,5	12,8	26	9	3	10	6	39	16	M8X1,25	45	4,5
32	49	9	M6	9	M8	12	1/8 G	7,5	14	32,5	10	3	12	7	44	19	M10X1,25	51	4,5
40	54,5	9	M6	9	M8	12	1/8 G	8	14,5	38	10	3	12	7	45	19	M10X1,25	52	5
50	65,5	12	M8	10,5	M10	16	1/8 G	8	14,5	46,5	13	4	16	8	45	22	M12X1,25	53	5
63	77	12	M8	10,5	M10	16	1/8 G	7,5	13,8	56,5	13	4	16	8	49	22	M12X1,25	57	5
80	95,5	12	M10	13,5	M12	20	1/8 G	8	15	72	17	4	20	10	54	28	M16X1,5	64	3
100	113,5	12	M10	13,5	M12	25	1/8 G	10,5	19,5	89	21	4	20	10	67	28	M16X1,5	77	3

+ = sommare corsa / plus stroke length

SEMPLICE EFFETTO MOLLA POSTERIORE - SINGLE ACTING REAR SPRING

CASPON(M/F) - CASPOM(M/F)

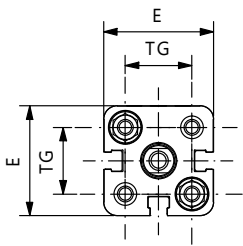

Ø20 - Ø25

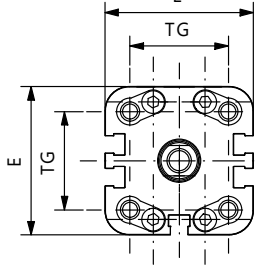

Ø32

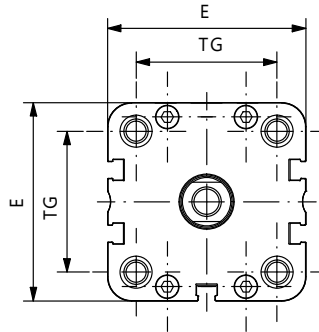

Ø40 - Ø50

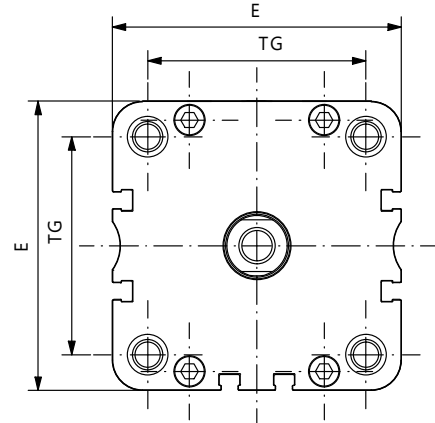

Ø63 - Ø80 - Ø100

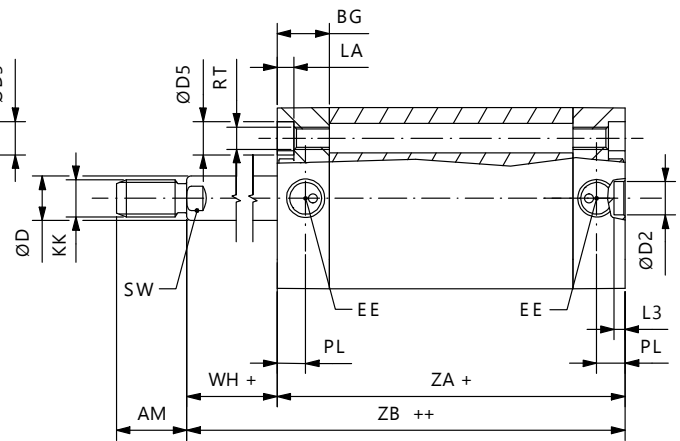
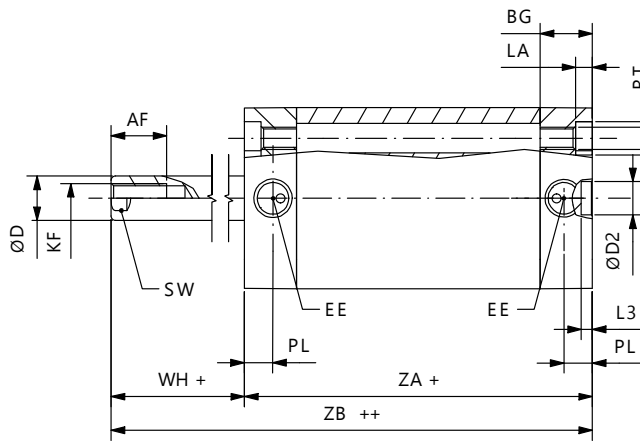

Ø	E	ØD2	RT	ØD5	KF	ØD	EE	PL	BG	TG	SW	L3	AF	WH	ZA	AM	KK	ZB	LA
20	36	9	M5	7,5	M6	10	M5	7,5	11,8	22	9	3	10	6	37	16	M8X1,25	43	4,5
25	40	9	M5	7,5	M6	10	M5	7,5	12,8	26	9	3	10	6	39	16	M8X1,25	45	4,5
32	49	9	M6	9	M8	12	1/8 G	7,5	14	32,5	10	3	12	7	44	19	M10X1,25	51	4,5
40	54,5	9	M6	9	M8	12	1/8 G	8	14,5	38	10	3	12	7	45	19	M10X1,25	52	5
50	65,5	12	M8	10,5	M10	16	1/8 G	8	14,5	46,5	13	4	16	8	45	22	M12X1,25	53	5
63	77	12	M8	10,5	M10	16	1/8 G	7,5	13,8	56,5	13	4	16	8	49	22	M12X1,25	57	5
80	95,5	12	M10	13,5	M12	20	1/8 G	8	15	72	17	4	20	10	54	28	M16X1,5	64	3
100	113,5	12	M10	13,5	M12	25	1/8 G	10,5	19,5	89	21	4	20	10	67	28	M16X1,5	77	3

+ = sommare corsa / plus stroke length

++ = sommare 2 x corsa / plus stroke length x 2

DOPPIO EFFETTO - DOUBLE ACTING

CADE0N(M/F) - CADE0M(M/F)

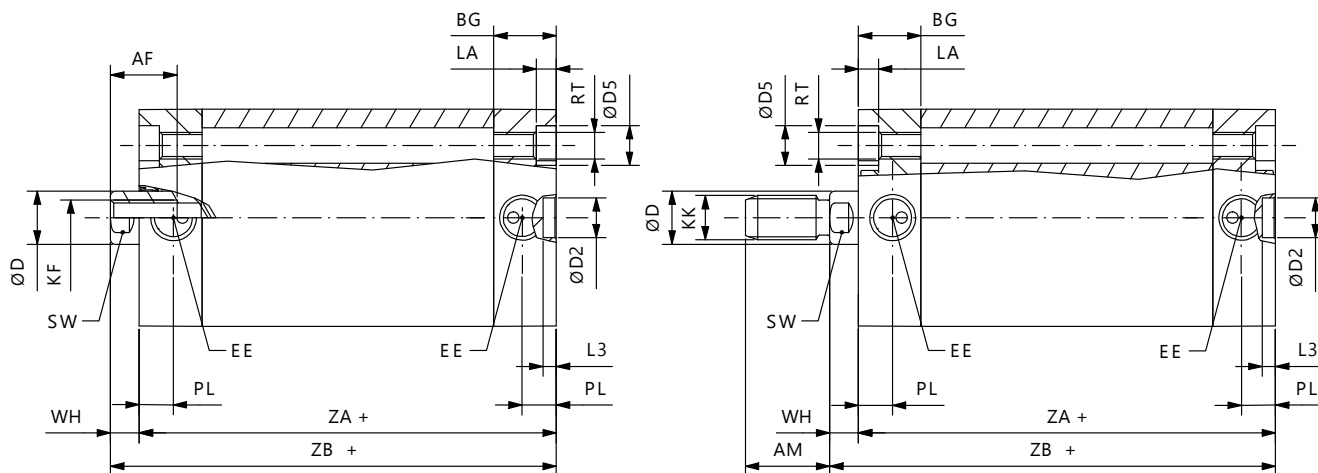
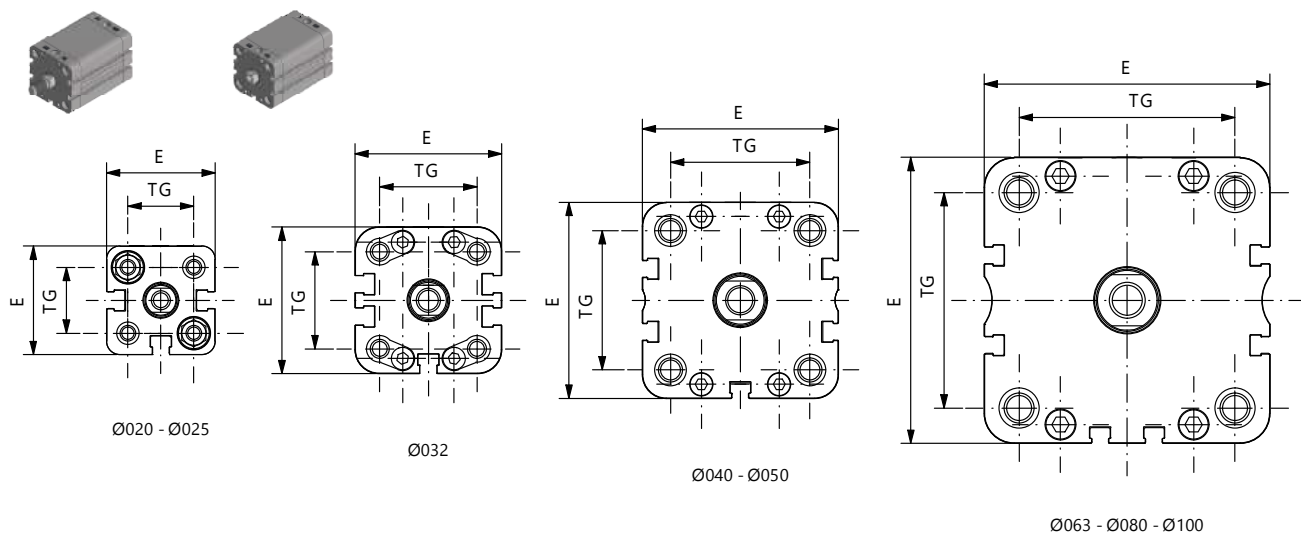

Ø	E	ØD2	RT	ØD5	KF	ØD	EE	PL	BG	TG	SW	L3	AF	WH	ZA +	AM	KK	ZB	LA
20	36	9	M5	7,5	M6	10	M5	7,5	11,8	22	9	3	10	6	37	16	M8X1,25	43	4,5
25	40	9	M5	7,5	M6	10	M5	7,5	12,8	26	9	3	10	6	39	16	M8X1,25	45	4,5
32	49	9	M6	9	M8	12	1/8 G	7,5	14	32,5	10	3	12	7	44	19	M10X1,25	51	4,5
40	54,5	9	M6	9	M8	12	1/8 G	8	14,5	38	10	3	12	7	45	19	M10X1,25	52	5
50	65,5	12	M8	10,5	M10	16	1/8 G	8	14,5	46,5	13	4	16	8	45	22	M12X1,25	53	5
63	77	12	M8	10,5	M10	16	1/8 G	7,5	13,8	56,5	13	4	16	8	49	22	M12X1,25	57	5
80	95,5	12	M10	13,5	M12	20	1/8 G	8	15	72	17	4	20	10	54	28	M16X1,5	64	3
100	113,5	12	M10	13,5	M12	25	1/8 G	10,5	19,5	89	21	4	20	10	67	28	M16X1,5	77	3

+ = sommare corsa / plus stroke length

DOPPIO EFFETTO PASSANTE - DOUBLE ACTING THROUGH ROD

CADE1N(M/F) - CADE1M(M/F)

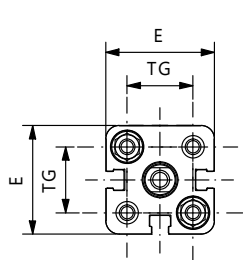

Ø20 - Ø25

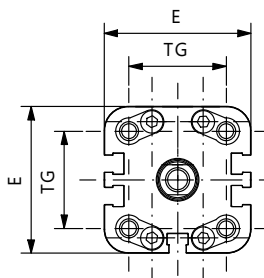

Ø32

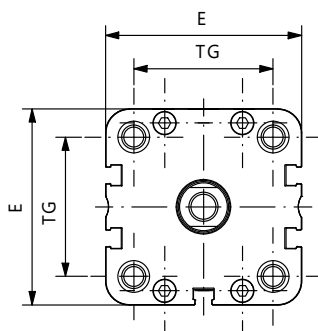

Ø40 - Ø50

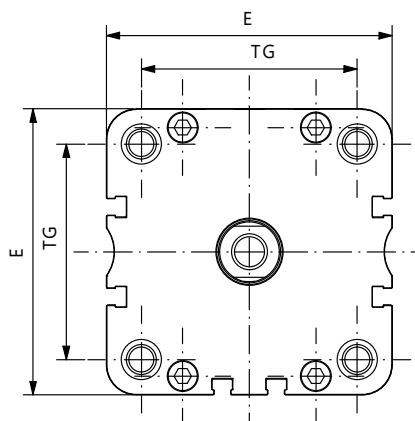

Ø63 - Ø80 - Ø100

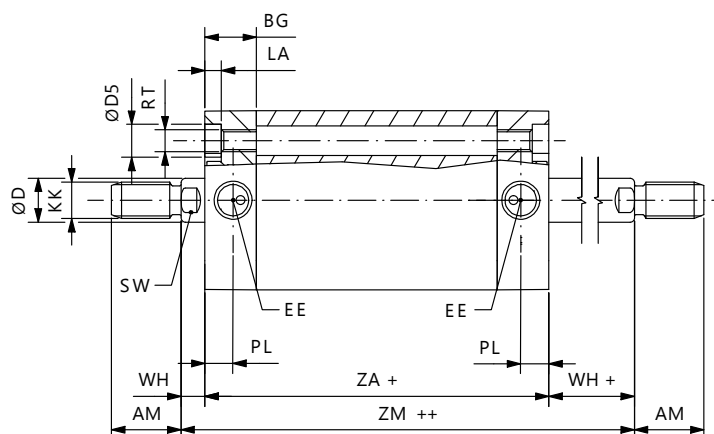
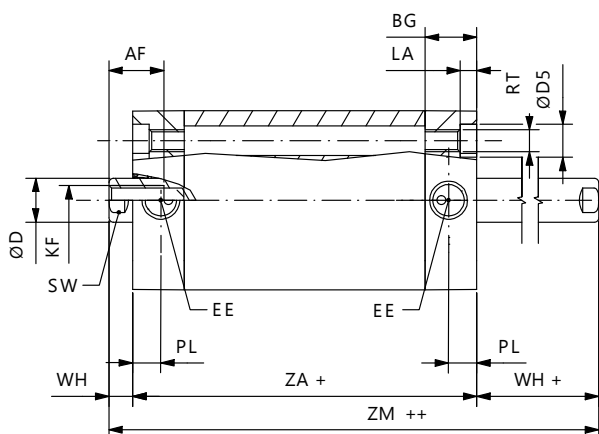

Ø	E	RT	ØD5	KF	ØD	EE	PL	BG	TG	SW	AF	WH	ZA +	AM	KK	ZM	LA
20	36	M5	7,5	M6	10	M5	7,5	11,8	22	9	10	6	37	16	M8X1,25	49	4,5
25	40	M5	7,5	M6	10	M5	7,5	12,8	26	9	10	6	39	16	M8X1,25	51	4,5
32	49	M6	9	M8	12	1/8 G	7,5	14	32,5	10	12	7	44	19	M10X1,25	58	5
40	54,5	M6	9	M8	12	1/8 G	8	14,5	38	10	12	7	45	19	M10X1,25	59	5
50	65,5	M8	10,5	M10	16	1/8 G	8	14,5	46,5	13	16	8	45	22	M12X1,25	61	5
63	77	M8	10,5	M10	16	1/8 G	7,5	13,8	56,5	13	16	8	49	22	M12X1,25	65	5
80	95,5	M10	13,5	M12	20	1/8 G	8	15	72	17	20	10	54	28	M16X1,5	74	3
100	113,5	M10	13,5	M12	25	1/8 G	10,5	19,5	89	21	20	10	67	28	M16X1,5	87	3

+ = sommare corsa / plus stroke length

++ = sommare 2 x corsa / plus stroke length x 2

DOPPIO EFFETTO ANTIROTAZIONE - DOUBLE ACTING NOT ROTATING

CADE0NF...E - CADE0MF...E

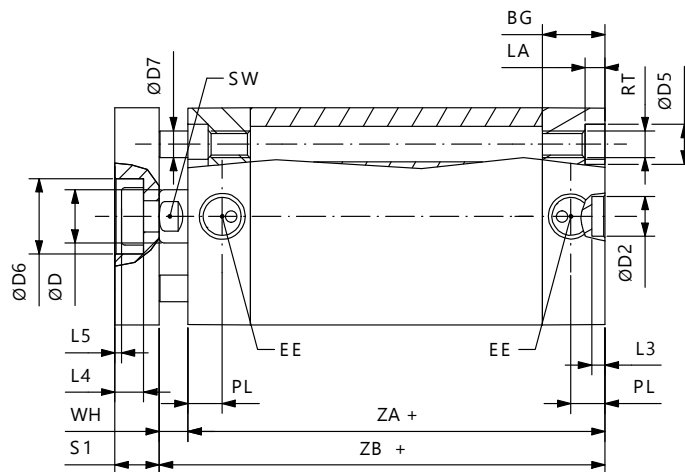
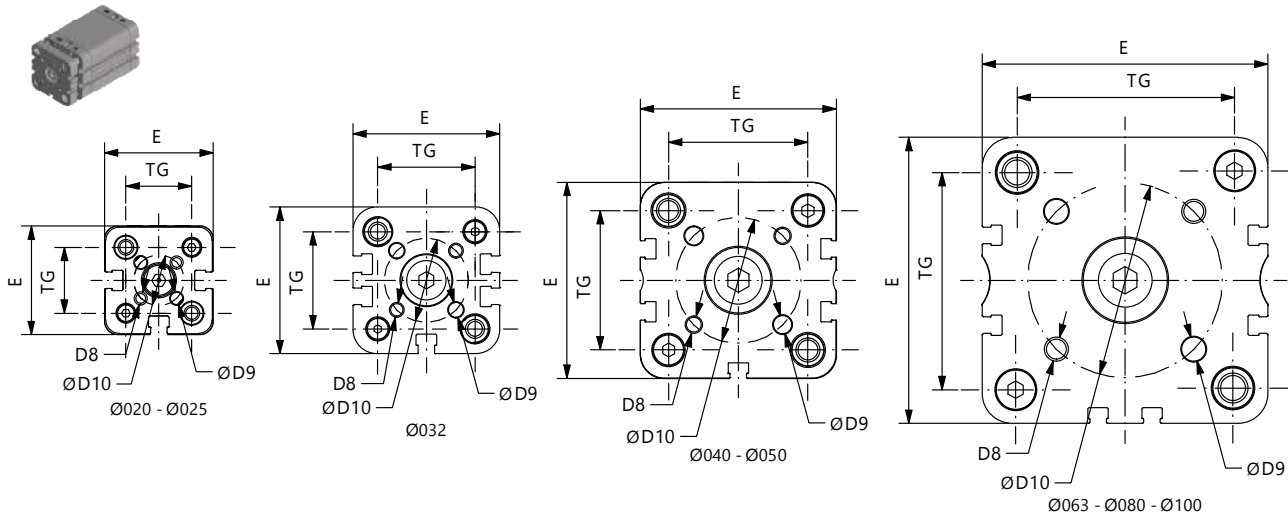
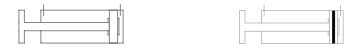

Ø	E	ØD2	RT	ØD5	ØD	EE	PL	BG	TG	SW	L3	WH	ZA	ZB	LA	S1	L4	ØD6	ØD7	ØD8	ØD9	ØD10
20	36	9	M5	7,5	10	M5	7,5	11,8	22	9	3	6	37	43	4,5	8	5	11	6	M4	4	17
25	40	9	M5	7,5	10	M5	7,5	12,8	26	9	3	6	39	45	4,5	8	5	14	6	M5	5	22
32	49	9	M6	9	12	1/8 G	7,5	14	32,5	10	3	7	44	51	4,5	10	6,5	17	6	M5	5	28
40	54,5	9	M6	9	12	1/8 G	8	14,5	38	10	3	7	45	52	5	10	6,5	17	8	M5	5	33
50	65,5	12	M8	10,5	16	1/8 G	8	14,5	46,5	13	4	8	45	53	5	12	7,5	22	10	M6	6	42
63	77	12	M8	10,5	16	1/8 G	7,5	13,8	56,5	13	4	8	49	57	5	12	7,5	22	10	M6	6	50
80	95,5	12	M10	13,5	20	1/8 G	8	15	72	17	4	10	54	64	3	14	9	28	14	M8	8	65
100	113,5	12	M10	13,5	25	1/8 G	10,5	19,5	89	21	4	10	67	77	3	14	10	30	14	M10	10	80

+ = sommare corsa / plus stroke length

DOPPIO EFFETTO PASSANTE ANTIROTAZIONE - DOUBLE ACTING THROUGH ROD NOT ROTATING

CADE1N(M/F)...E - CADE1M(M/F)...E

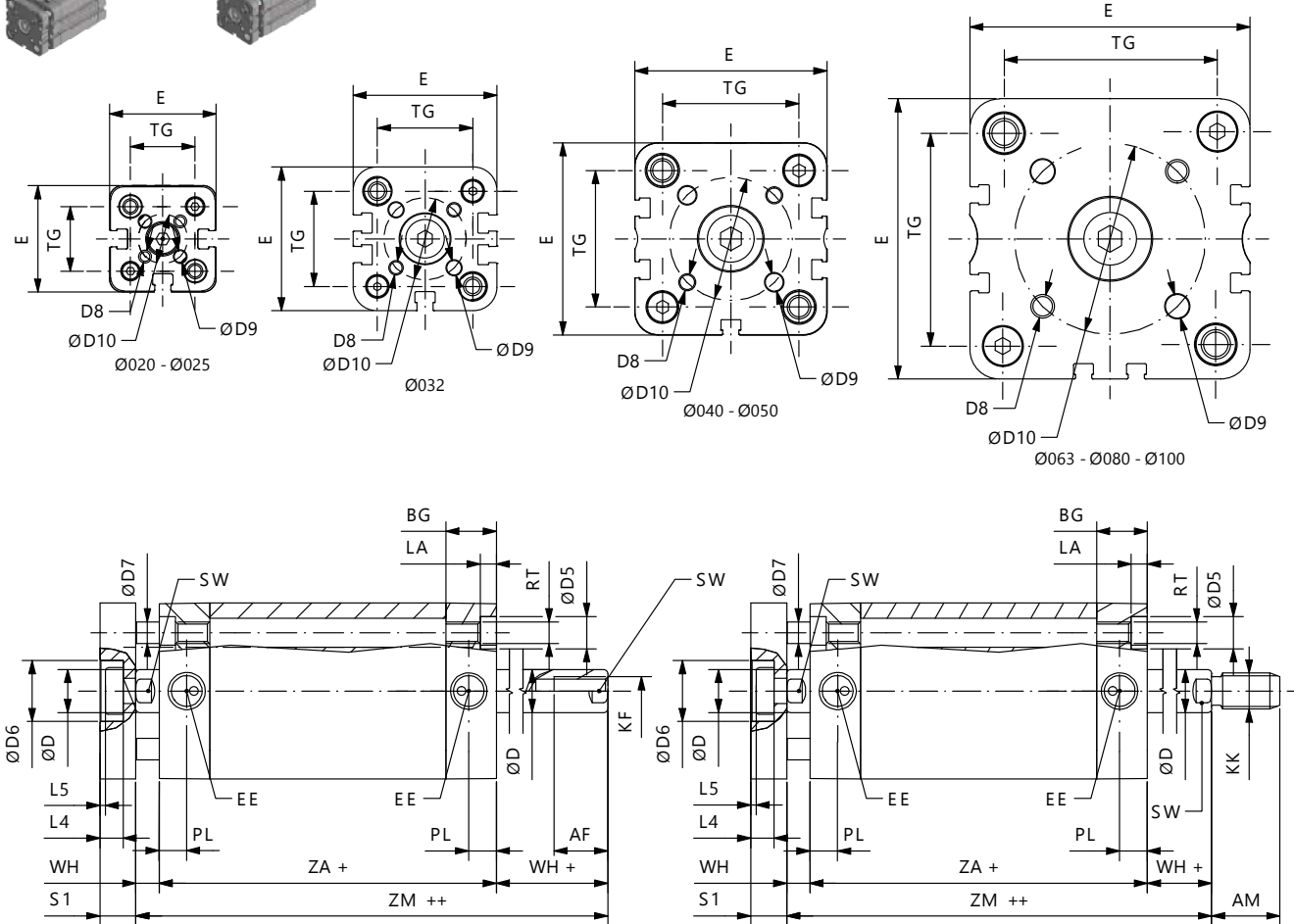

Ø	E	RT	ØD5	ØD	EE	PL	BG	TG	SW	WH	ZA	KK	ZM	LA	S1	L4	ØD6	ØD7	ØD8	ØD9	ØD10
20	36	M5	7,5	10	M5	7,5	11,8	22	9	6	37	M8X1,25	49	4,5	8	5	11	6	M4	4	17
25	40	M5	7,5	10	M5	7,5	12,8	26	9	6	39	M8X1,25	51	4,5	8	5	14	6	M5	5	22
32	49	M6	9	12	1/8 G	7,5	14	32,5	10	7	44	M10X1,25	58	4,5	10	6,5	17	6	M5	5	28
40	54,5	M6	9	12	1/8 G	8	14,5	38	10	7	45	M10X1,25	59	5	10	6,5	17	8	M5	5	33
50	65,5	M8	10,5	16	1/8 G	8	14,5	46,5	13	8	45	M12X1,25	61	5	12	7,5	22	10	M6	6	42
63	77	M8	10,5	16	1/8 G	7,5	13,8	56,5	13	8	49	M12X1,25	65	5	12	7,5	22	10	M6	6	50
80	95,5	M10	13,5	20	1/8 G	8	15	72	17	10	54	M16X1,5	74	3	14	9	28	14	M8	8	65
100	113,5	M10	13,5	25	1/8 G	10,5	19,5	89	21	10	67	M16X1,5	87	3	14	10	30	14	M10	10	80

+ = sommare corsa / plus stroke length

++ = sommare 2 x corsa / plus stroke length x 2

ACCESSORI DI FISSAGGIO - MOUNTING ACCESSORIES

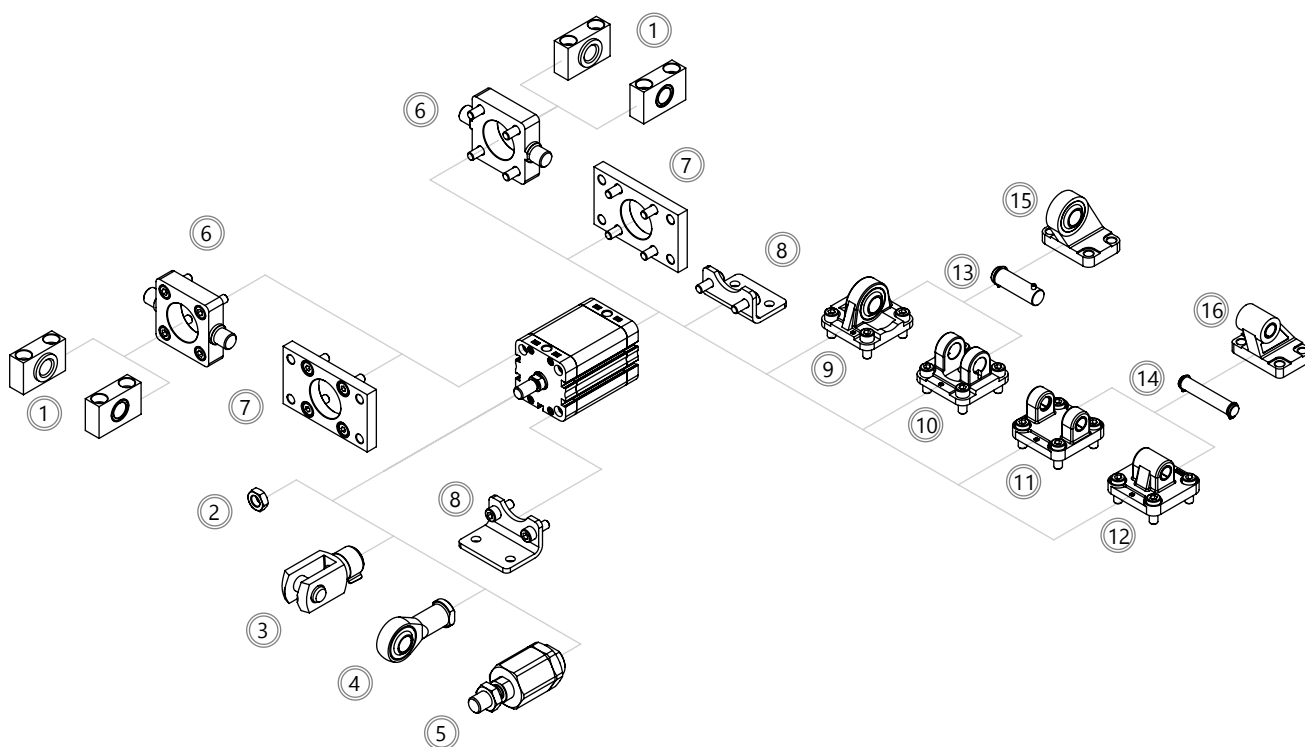

	Descrizione Description	Alluminio Aluminum	Acciaio Steel	Acciaio inox Stainless steel
1	Supporto per cerniera intermedia AT4 Support for intermediate hinge AT4	-	170	-
2	Dado stelo Piston rod nut	-	154	178
3	Forcella Clevis	-	152	177
4	Testa a snodo Rod end	-	153	177
5	Giunto autoallineante Self-aligning joint	-	153	-
6	Cerniera anteriore-posteriore MT5/MT6 Front-rear trunnion MT5/MT6	-	169	-
7	Flangia Flange	-	167	185
8	Piedino basso MS1 Low rise pedestral MS1	-	167	185
9	Cerniera maschio snodata MP6 Male hinge with spherical head MP6	162	166	184
10	Cerniera femmina stretta AB6 Narrow female hinge AB6	162	165	183
11	Cerniera femmina MP2 Female hinge MP2	160	164	181
12	Cerniera maschio MP4 Male hinge MP4	160	164	181
13	Perno antirotazione AA6 Not rotating pin AA6	-	163	183
14	Perno ISO AA4 ISO Pin AA4	-	161	182
15	Articolazione a squadra con testina snodata DIN 648K Square joint w spherical head DIN 648K	-	166	184
16	Articolazione a squadra AB7 Square join AB7	161	165	182

KIT DI MONTAGGIO - MOUNTING KIT

Contenuto del Kit - Kit parts
Kit cilindro doppio effetto magnetico Kit for double acting magnetic cylinder
Testata anteriore completa / Complete front cover
Testata posteriore completa / Complete rear cover
Pistone completo / Complete piston
Tappi protezione alimentazioni / Air supply protection caps
CADE0MMØK001



Kit disponibile anche nelle altre versioni.
 Kit available also in other versions.

ASTA STELO - PISTON ROD BAR

Ø cilindro cylinder Ø	Barra stelo - Piston rod bar		Ø stelo Piston rod Ø
	Barra stelo in AISI303 AISI303 Piston rod bar	Barra stelo in AISI316 AISI316 Piston rod bar	
20	V30BRT0310000	V30BRT0510000	10
25	V30BRT0310000	V30BRT0510000	10
32	V30BRT0312000	V30BRT0512000	12
40	V30BRT0312000	V30BRT0512000	12
50	V30BRT0316000	V30BRT0516000	16
63	V30BRT0316000	V30BRT0516000	16
80	V30BRT0320000	V30BRT0520000	20
100	V30BRT0325000	V30BRT0525000	25



Barre lunghezza 3 metri
 3 meter long bars

BARRA TUBO - TUBE BAR

Ø cilindro cylinder Ø	Barra tubo - Tube bar
	Barra tubo in alluminio anodizzato Anodized aluminum tube bar
Ø20	V30TG10020000
Ø25	V30TG10025000
Ø32	V30TG10032000
Ø40	V30TG10040000
Ø50	V30TG10050000
Ø63	V30TG10063000
Ø80	V30TG10080000
Ø100	V30TG100A0000
Ø125	V30TG100C5000

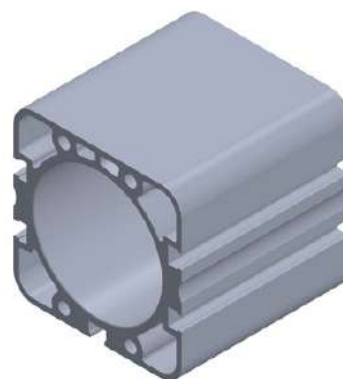

Barre lunghezza 3 metri
 3 meter long bars

Barre tubo e barre stelo disponibili anche lavorate e tagliate a misura/corsa.
 Tube bars and piston rod bars available also worked and cut at length/stroke.

