

# UNIC

Rustfrie cylindre – Teknisk katalog

2024



**HNC**  
GROUP

HNC Group er en del af  
**momentum**  
group

# UNIC

## STAINLESS CYLINDER

UNIC Stainless Cylinder er en serie af pneumatiske cylindre, som er udviklet og produceret af HNC Group. UNIC er et kvalitetsprodukt i rustfrit stål, som er tilpasset de høje krav fra fødevarer- og medicinalindustrien. UNIC er nemlig den mest rengøringsvenlige rustfrie cylinder på markedet, samtidig med at den er robust, så den kan tåle de skarpe rengøringsmidler, som især anvendes i disse industrier.

Igennem årene har HNC Group opbygget et meget stort standardprogram af cylindre fra Ø16 til Ø125 mm i diameter efter internationale standarder, som gør at HNC Group i dag har markedets bredeste standardprogram.

Udover det store sortiment af standardcylindre kan HNC Group fremstille specialcylindre ud fra den enkelte kundes ønsker.



# Et af de største standardprogrammer!

Ved hjælp af vores eget modulsystem indenfor rustfri stål cylindre og de engagerede medarbejdere i vores montageafdeling, garanterer vi markedets korteste leveringstid og et af de største standardprogrammer på markedet.

Vores service ligger langt over gennemsnittet – det står vi inde for.







UNIC er tilpasset fødevarer-  
og medicinalindustriens høje krav





# UNIC

## STAINLESS CYLINDER

Bestillingsnøgle	6
Standard cylinder DIN/ISO 6432	9-11
Standard cylinder DIN/ISO 15552	13-27
Stempelstangsløs cylinder	29-31
Kompaktcylinder ISO 21287	33-35
Festo kompatibel cylinder	37-39
Beslag og tilbehør	40-51
Specialcylindre	53
Reparationssæt for cylindre	54
Cylinderkræfter og luftforbrug	55

# Bestillingsnøgle

Ø25 x 80 = U025 0080 0512HA1  
①    ②            ③            ④    ⑤    ⑥    ⑦

1	UNIC Stainless Cylinder®	
2	Diameter (Ø)	
3	Slaglængde (mm)	
4	Forgavl	
5	Baggavl	
6	<b>Varmebestandig</b> cylinder	H
	<b>Kemikalieresistent</b> cylinder	C
	Cylinder med <b>PTFE</b> afstryger:	P
7	Cylinder med <b>adapter</b>	A1 eller A2

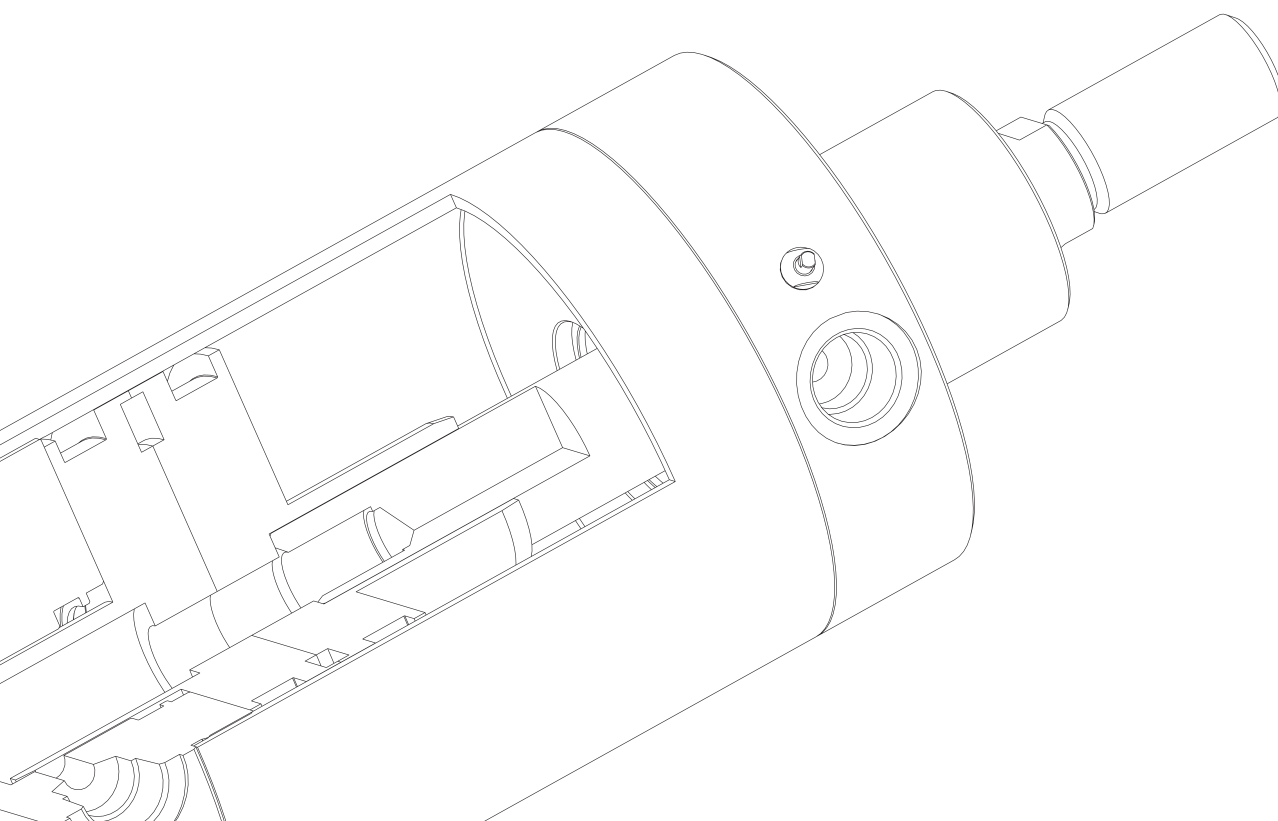





STAINLESS  
www.HICORGROUP.de  
Ø25 sl.100  
U025 0100 0104  
Hesse 8/4













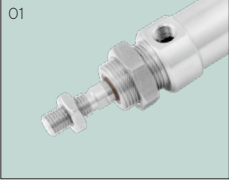
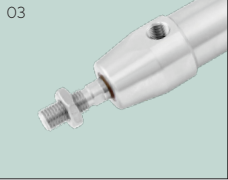
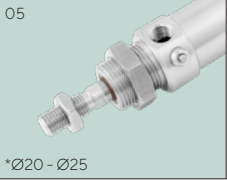

# Standard cylinder DIN/ISO 6432













Ø12 mm - Ø25 mm | 05-01-2024

**UNIC**  
STAINLESS CYLINDER

## Typeoversigt

Forgavle	01 	03 	05  *Ø20 - Ø25	07  *Ø20 - Ø25
	02 	04 	06 	
	08  *Ø20 - Ø25	10  *Ø20 - Ø25	12  *Ø20 - Ø25	
Baggavle				

Alle typer kan frit kombineres.

Beslag og tilbehør	 *Ø25	 *Ø25			
					
					

# Standard cylinder DIN/ISO 6432

Ø12 mm - Ø25 mm | 05-01-2024

**UNIC**  
 STAINLESS CYLINDER

## Specifikationer

Diameter	Ø12 mm - Ø25 mm
Standard	DIN/ISO 6432
Max tryk	3 bar til 10 bar
Temperatur	-20°C til +80°C
Standard slaglængder	10-500 mm

## Materialer

Stempelstang, Beslag, Cylinderrør, Endegavle, Adapter	AISI 304 / (EN 1.4301)
Stempel	POM / Aluminium
Skraber	Nitrilgummi / Polyuretan
O-ringe	Viton

## Standard

Magnet for aftastning
Justerbar endeslagsdæmpning (Kun Ø20 og Ø25)

## Optioner

AISI 316L (EN 1.4404)
ATEX
Cylinder med øget kemikalieresistens
Varmebestandig cylinder op til +150°C
Adapter
Fjeder retur eller frem
Kundetilpasset efter ønske
Renovering / Rep.sæt (Side 54)

## Bestillingsnøgle

 Ø25 x 125 mm = **U025 0125 0302C**

<b>Varmebestandig</b> cylinder	H
<b>Kemikalieresistent</b> cylinder	C
Cylinder med <b>adapter</b>	A1 eller A2

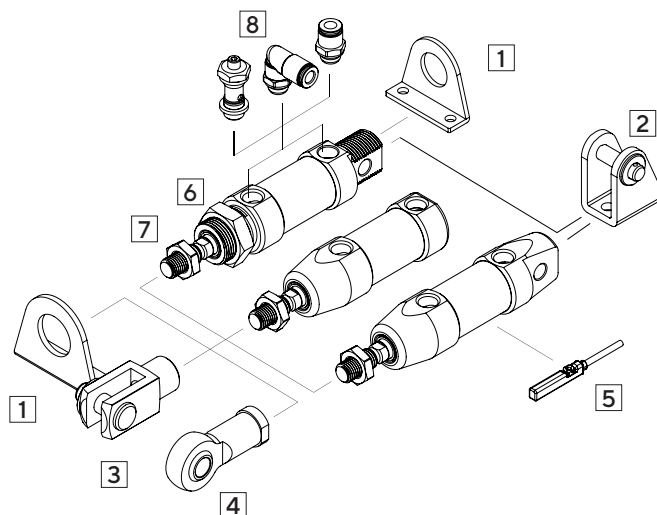

## Tilbehør

## Side ->

1	Fodbeslag	41
2	Drejebeslag 90°	41
3	Stempelstangsgaffel	40
4	Sfærisk ledøje	40
5	Reedsensor	48
6	Halsmøtrik	39
7	Stempelstangsmøtrik	39
8	Fittings	49

## Teoretiske cylinderkræfter opgivet i Newton

Cyl.Ø	st/st Ø	Stempelareal cm <sup>2</sup>		3 bar		4 bar		5 bar			
		•	o	•	o	•	o	•	o		
12	6	1,1	0,8	29	22	39	30	48	37		
16	6	2,0	1,7	53	46	70	61	88	76		
20	8	3,1	2,6	82	69	109	92	136	114		
25	10	4,9	4,1	129	108	172	144	216	180		
		6 bar		7 bar		8 bar		9 bar		10 bar	
		•	o	•	o	•	o	•	o	•	o
58	45	68	52	77	60	87	67	97	75		
106	91	123	107	141	122	158	137	176	152		
164	137	191	160	218	183	246	206	273	229		
259	216	302	253	345	289	388	325	421	361		





# Standard cylinder DIN/ISO 6432

**UNIC**  
STAINLESS CYLINDER

Teknisk data | 05-01-2024

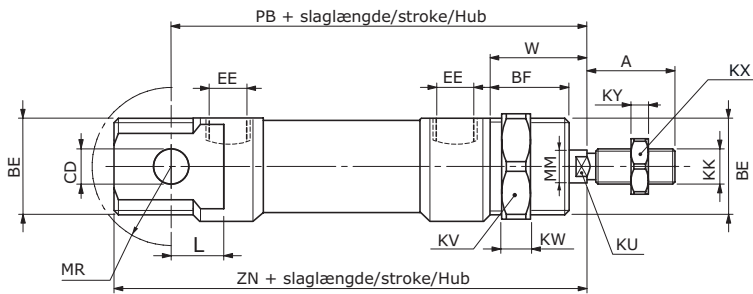

0102/0508

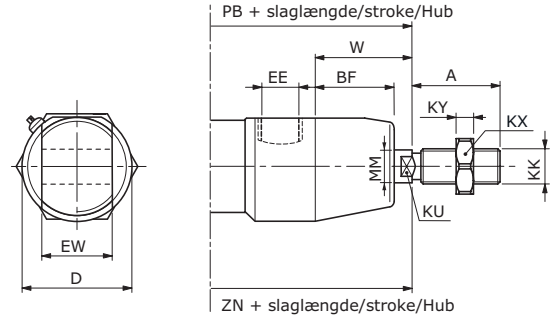

0302/0708

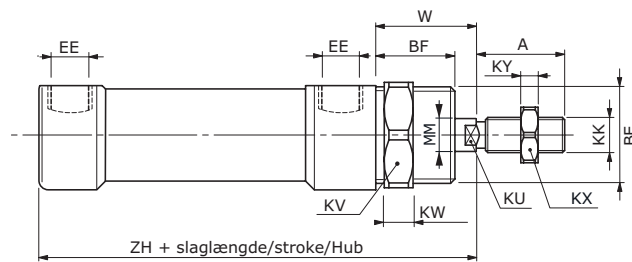

0104/0510

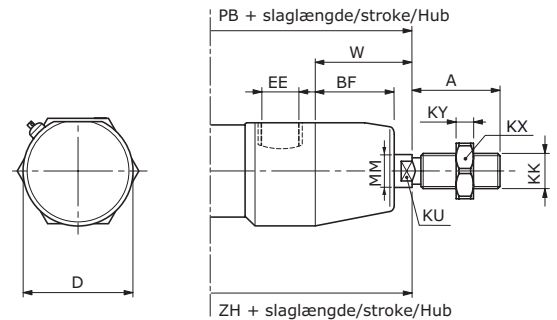

0304/0710

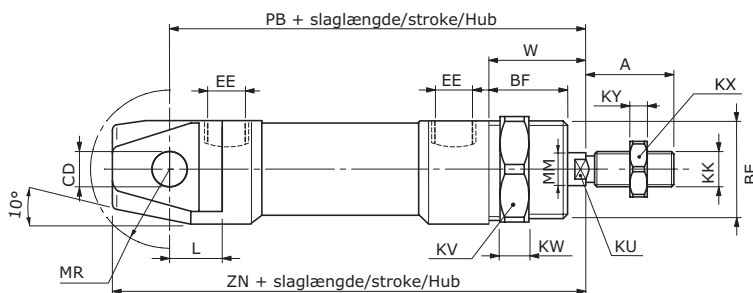

0106/0512

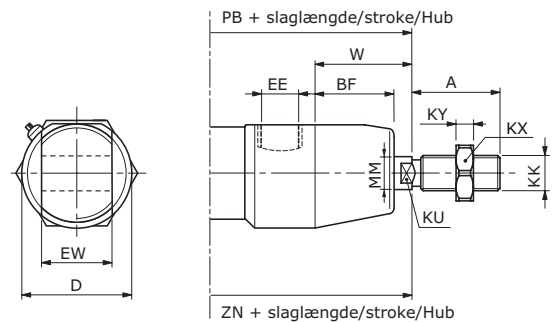

0306/0712

Ø	A	BE	BF	CD	D	EE	EW	KK	KU	KV	KW	KX	KY	L	MM	MR	PB	W	ZH	ZN
12	15	M16x1,5	15	Ø6	20	M5	12	M6	5	24	7	10	5	9	Ø6	12	75	20	69	86
16	16	M16x1,5	16	Ø6	20	M5	12	M6	5	24	7	10	5	9	Ø6	12	82	22	76	92
20	20	M22x1,5	18	Ø8	27	G1/8"	16	M8	6	27	7	13	4	12	Ø8	18	95	24	90	108
25	22	M22x1,5	21	Ø8	30	G1/8"	16	M10x1,25	8	27	7	17	5	12	Ø10	16	104,7	28,5	95,7	116,7

\*Bemærk. Alle mål er med 0,0 mm slaglængde.





# Standard cylinder DIN/ISO 15552

Ø32 mm - Ø63 mm | 05-01-2024

**UNIC**  
STAINLESS CYLINDER

		Typeoversigt				
Forgavle	09	11	05 *Ø20 - Ø25	07 *Ø20 - Ø25		
	14	16	18	24	26	
Baggavle						

Alle typer kan frit kombineres.

Beslag og tilbehør					



# Standard cylinder DIN/ISO 15552

Ø32 mm - Ø63 mm | 05-01-2024

**UNIC**  
STAINLESS CYLINDER

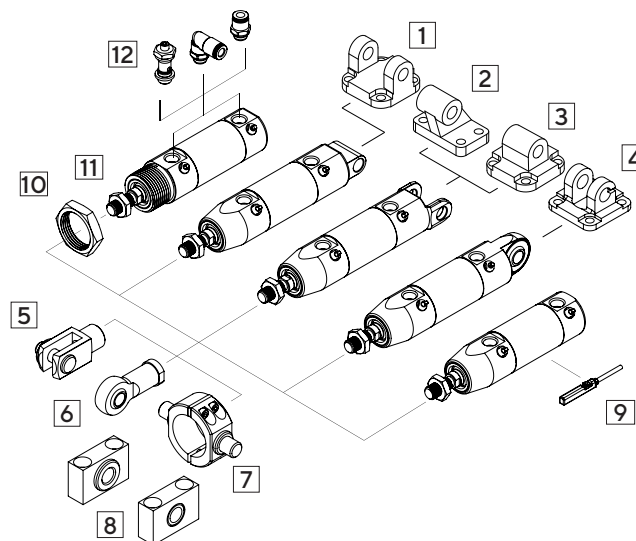
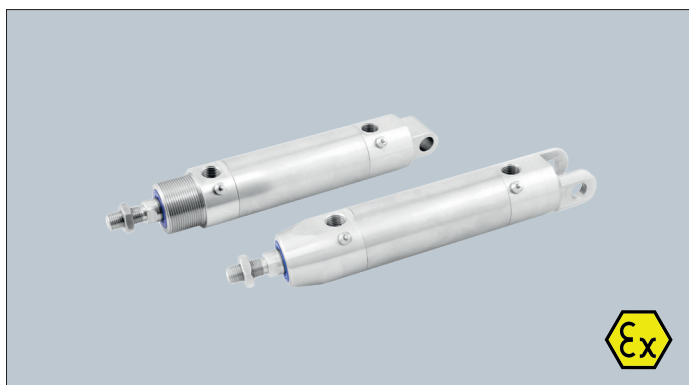

## Specifikationer

Diameter	Ø32 mm - Ø63 mm
Standard	DIN/ISO 15552
Arbejdsstryk	3 bar til 10 bar
Temperatur	-20°C til +80°C
Standard slaglængder	10-500 mm

## Materialer

Stempelstang, Beslag, Cylinderrør, Endegavle, Adapter	AISI 304 / (EN 1.4301)
Stempel	POM / Aluminium
Skraber	Nitrilgummi / Polyuretan
O-ringe	Viton

## Standard

Magnet for aftastning	
Justerbar endeslagsdæmpning	

## Optioner

AISI 316L (EN 1.4404)	
ATEX	
Cylinder med øget kemikalieresistens	
Varmebestandig cylinder op til +150°C	
Adapter	
Fjeder retur eller frem	
Kundetilpasset efter ønske	
Renovering / Rep.sæt (Side 54)	

## Bestillingsnøgle

Ø40 x 150 mm = <b>U040 0150 0918P</b>	
<b>Varmebestandig</b> cylinder	H
<b>Kemikalieresistent</b> cylinder	C
Cylinder med <b>PTFE</b> afstryger:	P
Cylinder med <b>adapter</b>	A1 eller A2

Tilbehør	Side ->
1 Gaffelbeslag	43
2 Drejebeslag 90°	42
3 Drejebeslag	42
4 Smalt gaffelbeslag	45
5 Stempelstangsgaffel	28
6 Sfærisk ledøje	28
7 Central drejebeslag	32
8 Lejebuk for drejebeslag	33
9 Reedsensor	48
10 Halsmøtrik	39
11 Stempelstangsmøtrik	39
13 Fittings	49

## Teoretiske cylinderkræfter opgivet i Newton

Cyl.Ø	st/st Ø	Stempelareal cm <sup>2</sup>		3 bar		4 bar		5 bar			
		•	o	•	o	•	o	•	o		
32	12	8	6,9	212	182	282	243	352	304		
40	16	12,6	10,6	33	282	444	373	554	466		
50	20	19,6	16,5	517	436	581	862	726	1035		
63	20	31,1	28	824	739	1098	986	1373	1232		
		6 bar		7 bar		8 bar		9 bar		10 bar	
		•	o	•	o	•	o	•	o	•	o
		422	364	493	425	563	486	634	546	704	607
		665	560	776	653	887	746	998	842	1109	933
		1035	871	1207	1016	1380	1162	1552	1307	1725	1452
		1647	1478	1923	1725	2196	1971	2471	2218	2746	2464



# Standard cylinder DIN/ISO 15552

**UNIC**  
STAINLESS CYLINDER

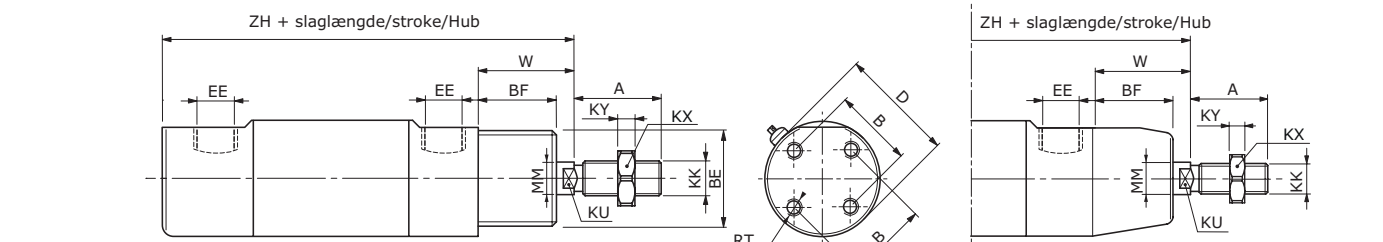
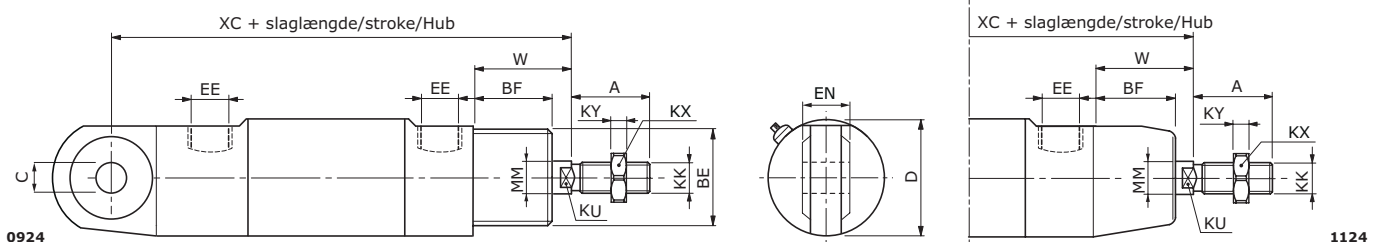
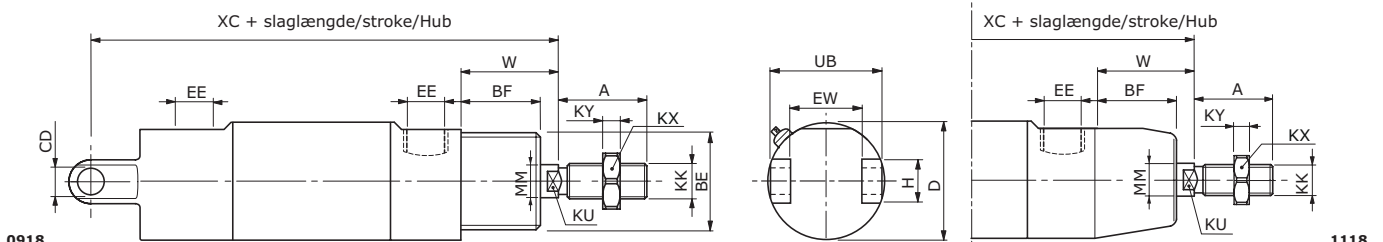
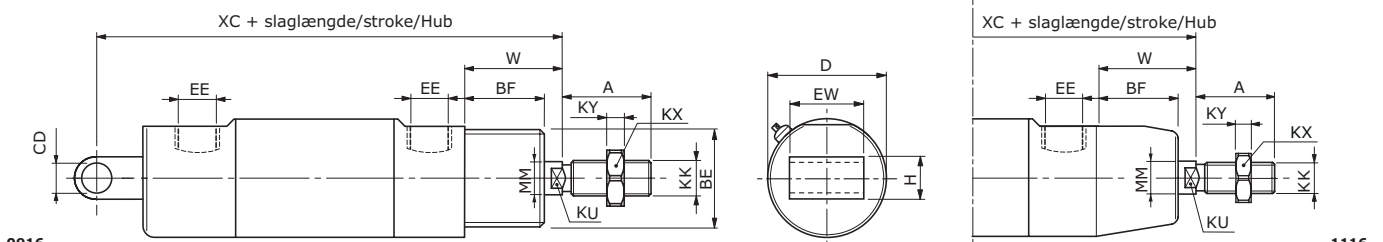
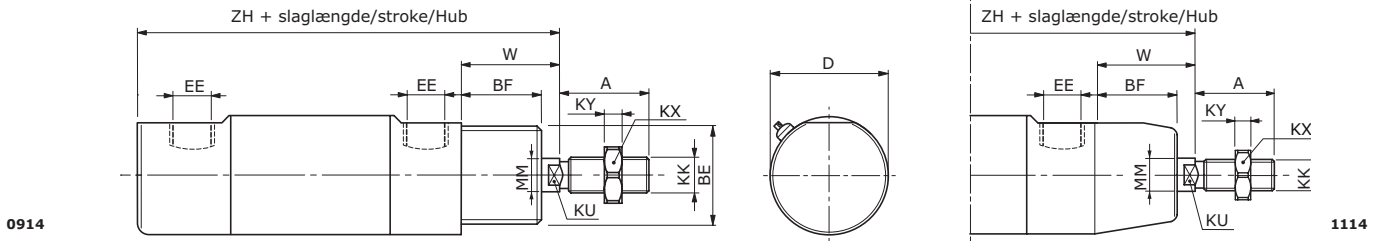

Ø	A	B	BE	BF	C	CD	D	EE	EW	H	KK	KU	KX	KY	MM	RT	W	XC	ZH
32	22	25	M30x1,50	20	Ø10	Ø10	33,60	G1/8"	26	15	M10x1,25	10	17	5	Ø12	M5	27	143	121
40	24	32	M36x1,50	22	Ø12	Ø12	41,60	G1/4"	28	20	M12x1,25	13	19	6	Ø16	M6	31	161	136
50	32	38	M42x1,50	29	Ø16	Ø12	52,40	G1/4"	32	20	M16x1,50	17	24	6	Ø20	M8	38	171	144
63	32	38	M42x1,50	29	Ø16	Ø16	65,40	G"3/8"	40	22	M16x1,50	17	24	6	Ø20	M8	38	191	159

\*Bemærk. Alle mål er med 0,0 mm slaglængde.









# Standard cylinder DIN/ISO 15552

Ø80 mm - Ø125 mm | 05-01-2024

**UNIC**  
STAINLESS CYLINDER

		Typeoversigt	
Forgavle	13		17
Baggavle	20		28

Alle typer kan frit kombineres.

Beslag og tilbehør					
					
					
					





# Standard cylinder DIN/ISO 15552

Teknisk data | 05-01-2024

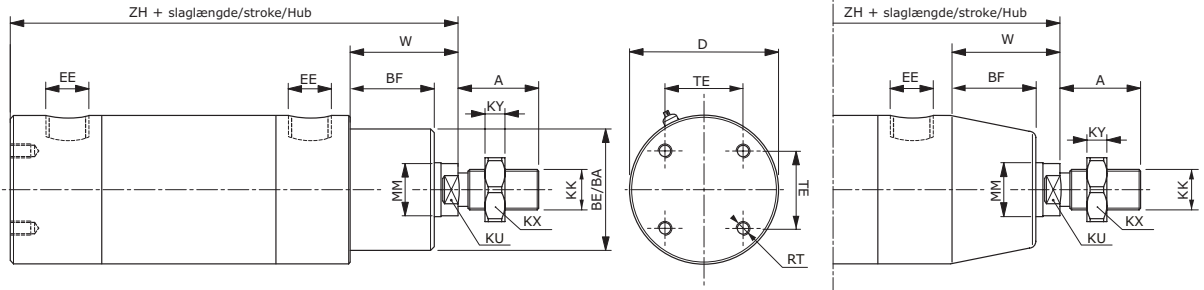

1320/1720

1120

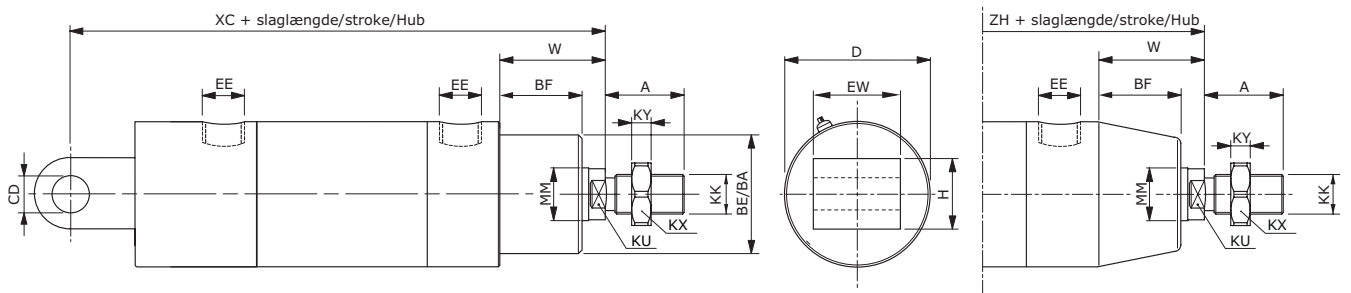

1328/1728

1128

Ø	A	BE <sup>2)</sup>	BA <sup>1)</sup>	BF	CD	D	EE	EW	H	KK	KU	KX	KY	MM	RT	TE	W	XC	ZH
80	40	M55x1,50	Ø55	35	16	Ø86	G3/8"	50	32	M20x1,50	22	30	9	Ø25	M8	45	46	211	175
100	40	M55x1,50	Ø55	38	20	Ø106	G1/2"	60	34	M20x1,50	22	30	9	Ø25	M10	55	51	230	190
125	54	M60x2	Ø60	50	30	Ø132	G1/2"	70	40	M27x2	27	41	13,50	Ø32	M12	70	65	275	226

\*Bemærk. Alle mål er med 0,0 mm slaglængde.

<sup>1)</sup> Cylinder med cylindrisk forgavl (nr.13) <sup>2)</sup> Cylinder med forgavl med gevind (nr.17)







# Standard cylinder DIN/ISO 15552

Ø32 mm - Ø125 mm (VDMA) | 05-01-2024

**UNIC**  
STAINLESS CYLINDER

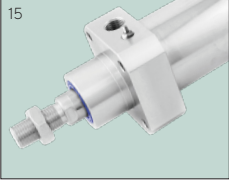
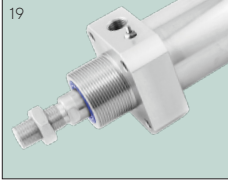
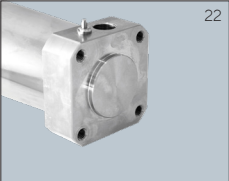
Typeoversigt	
Forgavle	<div style="display: flex; justify-content: space-around;"> <div style="text-align: center;"> <p>15</p>  </div> <div style="text-align: center;"> <p>19</p>  </div> </div>
Baggavle	<div style="text-align: center;"> <p>22</p>  </div>

Alle typer kan frit kombineres.

Beslag og tilbehør					
					
					
					

# Standard cylinder DIN/ISO 15552

Ø32 mm - Ø125 mm (VDMA) | 05-01-2024

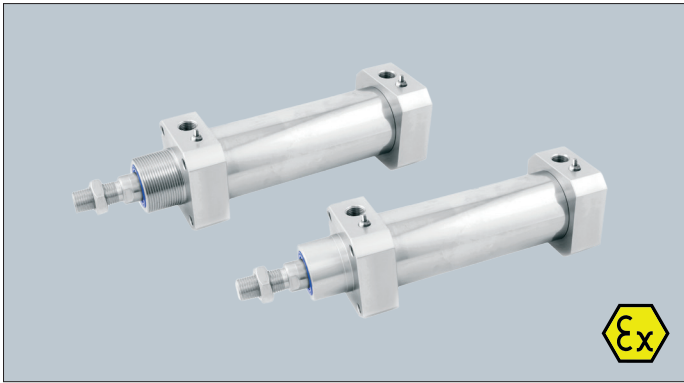

## Specifikationer

Diameter	Ø32 mm - Ø125 mm
Standard	DIN/ISO 15552
Arbejdstryk	3 bar til 10 bar
Temperatur	-20°C til +80°C
Standard slaglængder	10-500 mm

## Materialer

Stempelstang, Beslag, Cylinderrør, Endegavle, Adapter	AISI 304 / (EN 1.4301)
Stempel:	POM / Aluminium
Skraber:	Nitrilgummi / Polyuretan
O-ringe:	Viton

## Standard

Magnet for aftastning	
Justerbar endeslagsdæmpning	

## Optioner

AISI 316L (EN 1.4404)	
ATEX	
Cylinder med øget kemikalieresistens	
Varmebestandig cylinder op til +150°C	
Adapter	
Fjeder retur eller frem	
Kundetilpasset efter ønske	
Renovering / Rep.sæt (Side 54)	

## Bestillingsnøgle

Ø100 x 200 mm = <b>U100 0200 1922A1</b>	
<b>Varmebestandig</b> cylinder	H
<b>Kemikalieresistent</b> cylinder	C
Cylinder med <b>PTFE</b> afstryger:	P
Cylinder med <b>adapter</b>	A1 eller A2

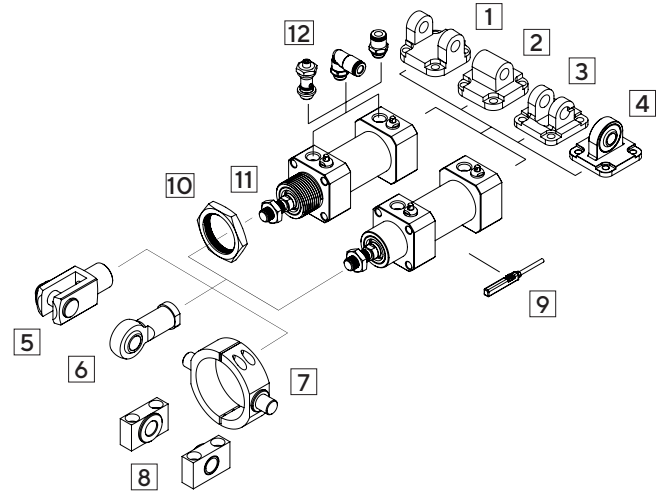

## Tilbehør

	Side ->
1 Gaffelbeslag	43
2 Drejebeslag	42
3 Smalt gaffelbeslag	45
4 Beslag med ledøje	44
5 Stempelstangsgaffel	40
6 Sfærisk ledøje	40
7 Central drejebeslag	46
8 Lejebuk for drejebeslag	47
9 Reedsensor	48
10 Halsmøtrik	39
11 Stempelstangsmøtrik	39
12 Fittings	49

## Teoretiske cylinderkræfter opgivet i Newton

Cyl.Ø	st/st Ø	Stempelareal cm <sup>2</sup>		3 bar		4 bar		5 bar			
		•	o	•	o	•	o	•	o		
32	12	8,0	6,9	212	182	282	243	352	304		
40	16	12,6	10,6	333	282	444	373	554	466		
50	20	19,6	16,5	517	436	690	581	862	726		
63	20	31,1	28,0	824	739	1098	986	1373	1232		
80	25	50,3	45,3	1328	1199	1771	1598	2213	1998		
100	25	78,5	73,6	2072	1943	2763	2591	3454	3238		
125	32	122,7	114,6	3239	3028	4319	4037	5399	5047		
		6 bar		7 bar		8 bar		9 bar		10 bar	
		•	o	•	o	•	o	•	o	•	o
422	364	493	425	563	486	634	546	704	607		
665	560	776	653	887	746	998	840	1109	933		
1035	871	1207	1016	1380	1162	1552	1307	1725	1452		
1647	1478	1923	1725	2196	1971	2471	2218	2746	2464		
2656	2397	3098	2797	3541	3196	3984	3596	4426	3995		
4145	3886	4836	4534	5526	5181	6217	5829	6908	6477		
6479	6056	7558	7066	8638	8075	9718	9084	10798	10094		

# Standard cylinder DIN/ISO 15552

Teknisk data | 05-01-2024

**UNIC**  
STAINLESS CYLINDER

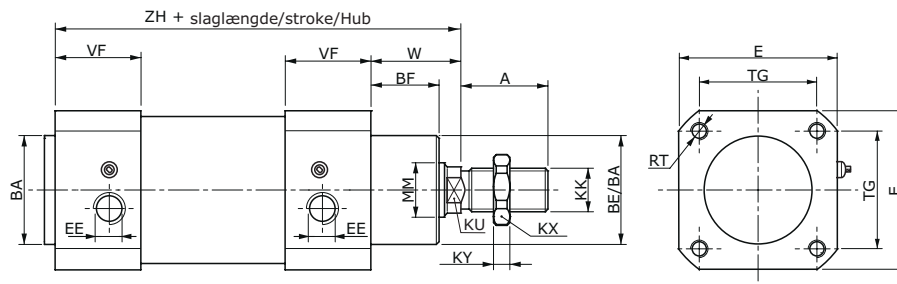

1522/1922

Ø	A	BE <sup>2)</sup>	BA <sup>1)</sup>	BF	E	EE	KK	KU	KX	KY	MM	RT	TG	VF	W	ZH
32	22	M30x1,50	Ø30	20	45	G1/8"	M10x1,25	NV10	NV17	5	Ø12	M6	32,50	23	27	121
40	24	M36x1,50	Ø35	22	55	G1/4"	M12x1,25	NV13	NV19	6	Ø16	M6	38	27,50	31	136
50	32	M42x1,50	Ø40	29	65	G1/4"	M16x1,50	NV17	NV24	6	Ø20	M8	46,50	26	38	144
63	32	M42x1,50	Ø40	29	75	G3/8"	M16x1,50	NV17	NV24	6	Ø20	M8	56,50	29,50	38	159
80	40	M55x1,50	Ø55	35	95	G3/8"	M20x1,50	NV22	NV30	9	Ø25	M10	72	31	47	175
100	40	M55x1,50	Ø55	38	115	G1/2"	M20x1,50	NV22	NV30	9	Ø25	M10	89	31	52	190
125	51	M60x2	Ø60	50	140	G1/2"	M27x2	NV27	NV41	13,50	Ø32	M12	110	39	66	226

\*Bemærk. Alle mål er med 0,0 mm slaglængde.

<sup>1)</sup> Cylinder med cylindrisk forgavl (nr.15) <sup>2)</sup> Cylinder med forgavl med gevind (nr.19)





# Standard cylinder DIN/ISO 15552

**UNIC**  
STAINLESS CYLINDER

Ø32 mm - Ø100 mm (Stagbolte) | 2130 | 05-01-2024

## Typeoversigt





# Standard cylinder DIN/ISO 15552

Ø32 mm - Ø100 mm (Stagbolte) | 2130 | 05-01-2024

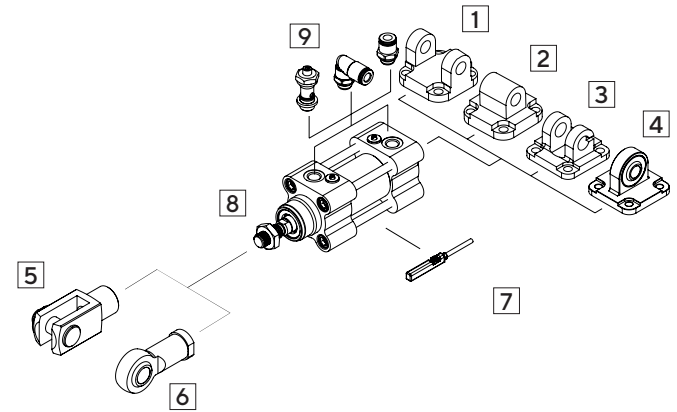
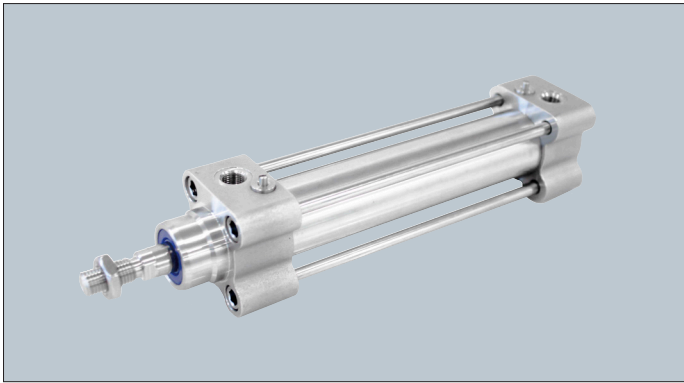
## Specifikationer

Diameter	Ø32 mm - Ø100 mm
Standard	DIN/ISO 15552
Arbejdstryk	3 bar til 10 bar
Temperatur	-20°C til +80°C
Standard slaglængder	25-1000 mm

## Materialer

Stempelstang, Beslag, Cylinderrør, Endegavle	AISI 304 / (EN 1.4301)
Stempel:	Aluminium
Skraber:	Nitrilgummi / Polyuretan
O-ringe:	Viton

## Standard

Magnet for aftastning
Justerbar endeslagsdæmpning

## Optioner

AISI 316L (EN 1.4404)
Fjeder retur eller frem
Kundetilpasset efter ønske
Renovering / Rep.sæt (Side 54)

## Bestillingsnøgle

Ø40 x 150 mm = **U040 0150 2130**

## Tilbehør

## Side ->

1	Gaffelbeslag	43
2	Drejebeslag	42
3	Smalt gaffelbeslag	45
4	Beslag med ledøje	44
5	Stempelstangsgaffel	40
6	Sfærisk ledøje	40
7	Reedsensor	48
8	Stempelstangsmøtrik	39
9	Fittings	49

## Teoretiske cylinderkræfter opgivet i Newton

Cyl.Ø	st/st Ø	Stempelareal cm <sup>2</sup>		3 bar		4 bar		5 bar			
		•	•	•	•	•	•	•	•		
32	12	8,0	6,9	212	182	282	243	352	304		
40	16	12,6	10,6	333	282	444	373	554	466		
50	20	19,6	16,5	517	436	690	581	862	726		
63	20	31,1	28,0	824	739	1098	986	1373	1232		
80	25	50,3	45,3	1328	1199	1771	1598	2213	1998		
100	25	78,5	73,6	2072	1943	2763	2591	3454	3238		
		6 bar		7 bar		8 bar		9 bar		10 bar	
		•	•	•	•	•	•	•	•	•	•
422	364	493	425	563	486	634	546	704	607		
665	560	776	653	887	746	998	840	1109	933		
1035	871	1207	1016	1380	1162	1552	1307	1725	1452		
1647	1478	1923	1725	2196	1971	2471	2218	2746	2464		
2656	2397	3098	2797	3541	3196	3984	3596	4426	3995		
4145	3886	4836	4534	5526	5181	6217	5829	6908	6477		

# Standard cylinder DIN/ISO 15552

Teknisk data | 05-01-2024

**UNIC**  
STAINLESS CYLINDER

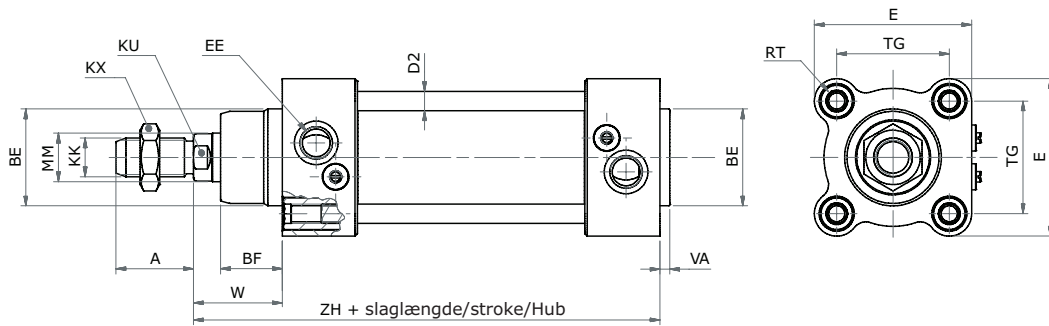

2130

Ø	A	BE	BF	E	EE	KK	KU	KX	D2	MM	RT	TG	W	ZH
32	22	Ø30	18	48	G1/8"	M10x1,25	10	17	6	Ø12	M6	32,5	26	121
40	24	Ø35	22	52	G1/4"	M12x1,25	13	19	6	Ø16	M6	38	30	136
50	32	Ø40	25,5	65	G1/4"	M16x1,50	17	24	8	Ø20	M8	46,5	37	144
63	32	Ø45	26	75	G3/8"	M16x1,50	17	24	8	Ø20	M8	56,5	37	159
80	40	Ø45	32	95	G3/8"	M20x1,50	22	30	10	Ø25	M10	72	46	175
100	40	Ø55	38	115	G1/2"	M20x1,50	22	30	10	Ø25	M10	89	51	190

\*Bemærk. Alle mål er med 0,0 mm slaglængde.





# Stempelstangsløs cylinder

Ø25 mm - Ø40 mm | 4040 / 4041 | 05-01-2024

**UNIC**  
STAINLESS CYLINDER

## Typeoversigt

Type

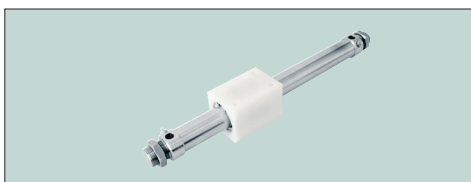

Beslag og  
tilbehør



# Stempelstangsløs cylinder

Ø25 mm - Ø40 mm | 4040 / 4041 | 05-01-2024

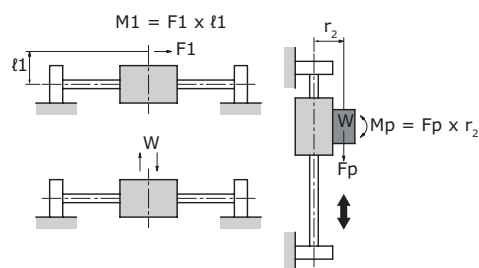
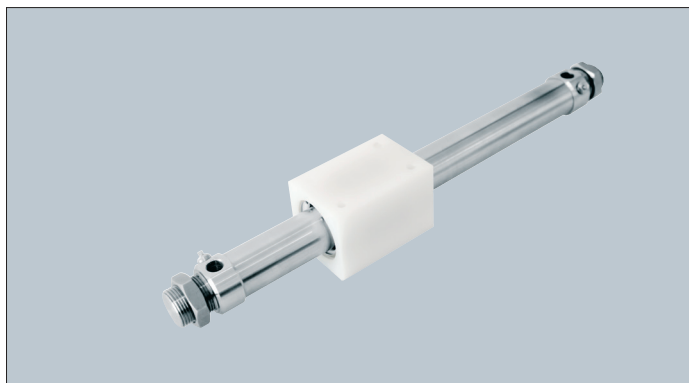
## Last og moment

Ø	Horizontal last W (kg)	Tilladt moment Mp (kgf · m)
25	6,8	3,92
32	9,7	8,83
40	15,8	13,70

## Tilbehør

Tilbehør	Side ->
Halsmøtrik	38
Fittings	49

## Specifikationer

Diameter	Ø25 mm - Ø40 mm
Arbejdstryk	3 bar til 10 bar
Temperatur	-20°C til +80°C
Standard slaglængder	10-500 mm

## Materialer

Stempelstang, Beslag, Cylinderrør, Endegavle	AISI 304 / (EN 1.4301)
Hus	POM-C FG (fødevaregodkendt) PTFE (varmebestandig)
Skraber:	Viton / Polyuretan
O-ringe:	Viton

## Standard

Justerbar endeslagsdæmpning

## Typer

4040	Uden førring
4041	Med førring (drejesikret)

## Bestillingsnøgle

Ø40 x 150 mm = U040 0150 4040

## Optioner

Varmebestandig cylinder op til +150°C

Kundetilpasset efter ønske

# Stempelstangsløs cylinder

Teknisk data | 05-01-2024

**UNIC**  
STAINLESS CYLINDER

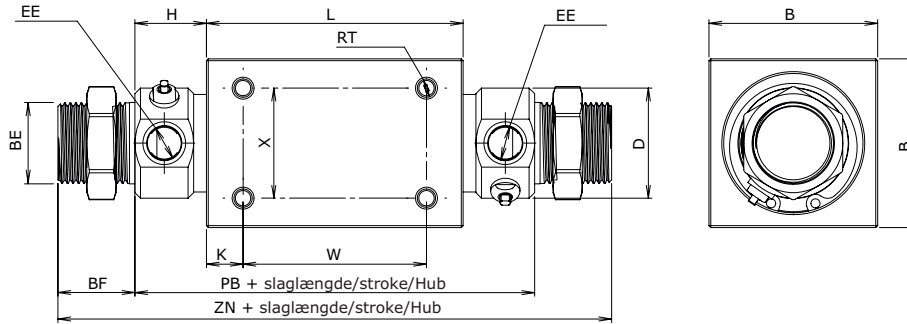

4040

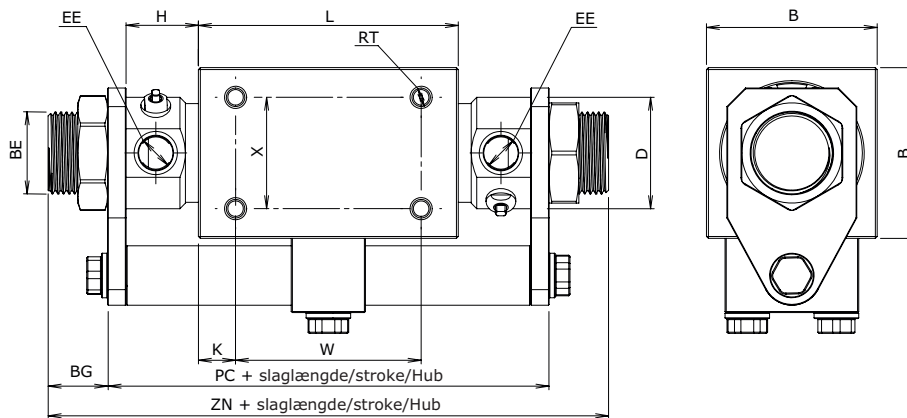

4041

Ø	B	BE	BF	BG	D	EE	H	K	L	PB	PC	RT	W	X	ZN
25	46	M22x1,50	21	16	30	G1/8"	20,50	10	70	109	119	M5	50	30	151
32	60	M30x1,50	20	15	33,60	G1/8"	22	15	80	135	145	M6	50	40	175
40	70	M38x1,50	22	17	46	G1/4"	29	16	92	148	158	M6	60	40	192

\*Bemærk. Alle mål er med 0,0 mm slaglængde.







# Kompaktcylinder ISO 21287

Ø20 mm - Ø100 mm | 5150 | 05-01-2024

**UNIC**  
STAINLESS CYLINDER

## Typeoversigt

Type	UG	IG	MF

Beslag og tilbehør					

# Kompaktcylinder ISO 21287

Ø20 mm - Ø100 mm | 5150 | 05-01-2024

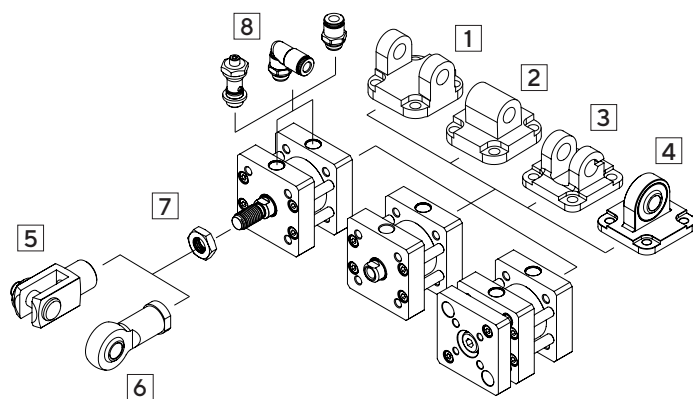
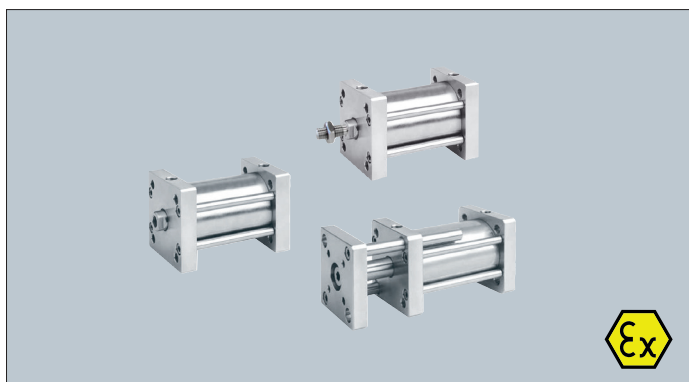
**UNIC**  
 STAINLESS CYLINDER

## Specifikationer

Diameter	Ø20 mm - Ø100 mm
Standard	ISO 21287
Max tryk	3 bar til 10 bar
Temperatur	-20°C til +80°C
Standard slaglængder	10-500 mm

## Materialer

Stempelstang, Beslag, Cylinderrør, Endegavle	AISI 304 / (EN 1.4301)
Stempel	Aluminium
Skraber	Nitrilgummi / Polyuretan
O-ringe	Viton

## Standard

Magnet for aftastning
Justerbar endeslagsdæmpning

## Optioner

AISI 316L (EN 1.4404)
ATEX
FDA
Kundetilpasset efter ønske
Renovering / Rep.sæt (Side 54)

## Typer

5150-UG	Udv. gevind på st.st
5150-IG	Indv. gevind i st.st
5150-MF	Med føring (drejesikret)

## Bestillingsnøgle

 Ø25 x 125 mm = **U025 0125 5150-UG**

## Tilbehør

## Side ->

1	Gaffelbeslag	43
2	Lige drejebeslag	42
3	Smalt gaffelbeslag	45
4	Beslag med ledøje	44
5	Stempelstangsgaffel	40
6	Sfærisk ledøje	40
7	Stempelstangsmøtrik	39
8	Fittings	49

## Teoretiske cylinderkræfter opgivet i Newton

Cyl.Ø	st/st Ø	Stempelareal cm <sup>2</sup>		3 bar		4 bar		5 bar			
		•	o	•	o	•	o	•	o		
20	8	3,1	2,6	82	69	109	92	136	114		
25	10	4,9	4,1	129	108	172	144	216	180		
32	12	8,0	6,9	212	182	282	243	352	304		
40	16	12,6	10,6	333	282	444	373	554	466		
50	20	19,6	16,5	517	436	690	581	862	726		
63	20	31,1	28,0	824	739	1098	986	1373	1232		
80	25	50,3	45,3	1328	1199	1771	1598	2213	1998		
100	25	78,5	73,6	2072	1943	2763	2591	3454	3238		
		6 bar		7 bar		8 bar		9 bar		10 bar	
		•	o	•	o	•	o	•	o	•	o
164	137	191	160	218	183	246	206	273	229		
259	216	302	253	345	289	388	325	421	361		
422	364	493	425	563	486	634	546	704	607		
665	560	776	653	887	746	998	840	1109	933		
1035	871	1207	1016	1380	1162	1552	1307	1725	1452		
1647	1478	1923	1725	2196	1971	2471	2218	2746	2464		
2656	2397	3098	2797	3541	3196	3984	3596	4426	3995		
4145	3886	4836	4534	5526	5181	6217	5829	6908	6477		



# Kompaktcylinder ISO 21287

Teknisk data | 05-01-2024

**UNIC**  
STAINLESS CYLINDER

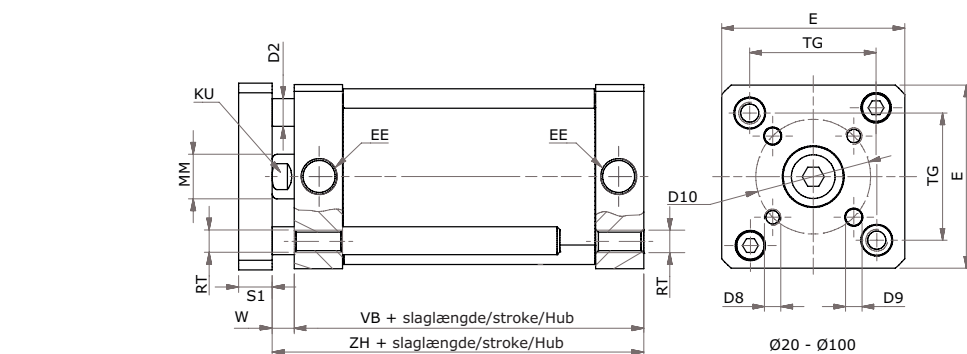
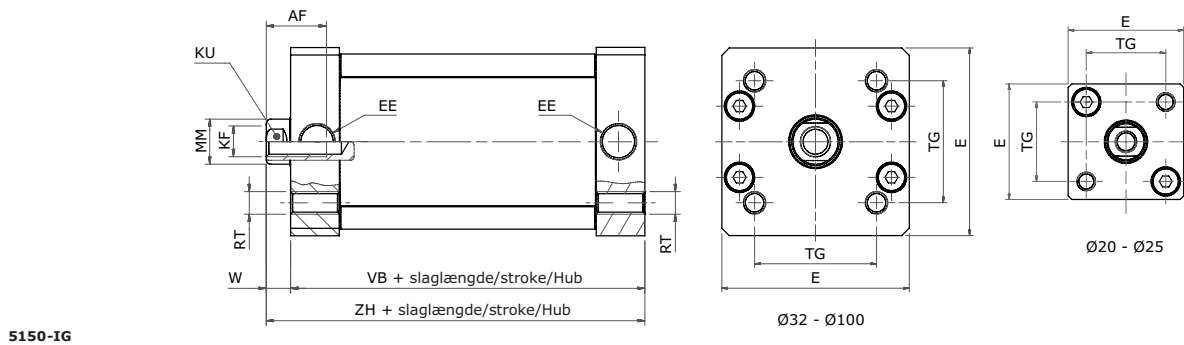
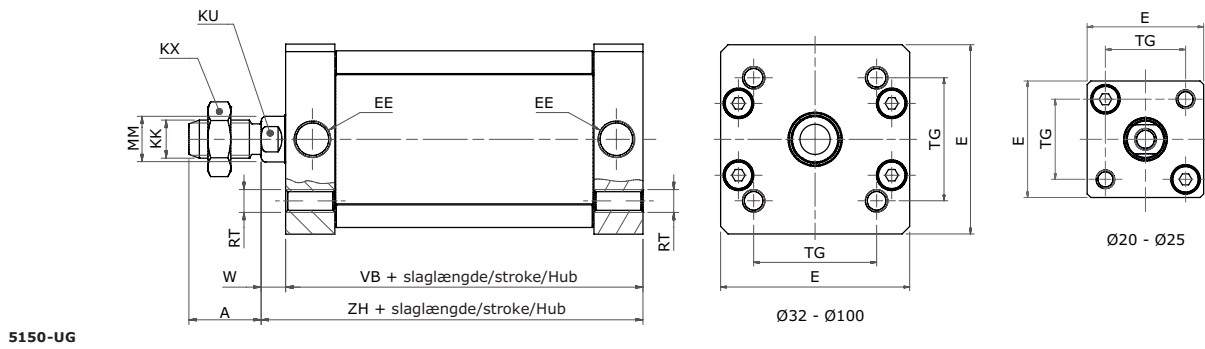

Ø	A	AF	D2	D8	D9	D10	E	EE	KF	KK	KU	KX	MM	RT	S1	TG	VB	W	ZH	Udv. gevind på st.st	Indv. gevind på st.st	Med føring
20	16	10	6	M4	4	17	32	M5	M6	M8	8	13	Ø10	M5	8	22	37	6,50	43,50	-UG	-IG	-MF
25	16	10	6	M5	5	22	36	M5	M6	M8	8	13	Ø10	M5	8	26	39	6	45	-UG	-IG	-MF
32	19	12	6	M5	5	28	50	G1/8"	M8	M10x1,25	10	17	Ø12	M6	10	32,50	44	6,50	50,50	-UG	-IG	-MF
40	19	12	8	M5	5	33	57	G1/8"	M8	M10x1,25	10	17	Ø12	M6	10	38	45	7	52	-UG	-IG	-MF
50	22	16	10	M6	6	42	67	G1/8"	M10	M12x1,25	13	19	Ø16	M8	12	46,50	45	8	53	-UG	-IG	-MF
63	22	16	10	M6	6	50	80	G1/8"	M10	M12x1,25	13	19	Ø16	M8	12	56,50	49	8	57	-UG	-IG	-MF
80	28	20	12	M8	8	65	96	G1/8"	M12	M16x1,50	17	24	Ø20	M10	14	72	54	10	64	-UG	-IG	-MF
100	28	20	14	M10	10	80	116	G1/8"	M12	M16x1,50	22	24	Ø25	M10	14	89	67	10	77	-UG	-IG	-MF

\*Bemærk. Alle mål er med 0,0 mm slaglængde.





# Festo kompatibel cylinder

Ø32 mm - Ø63 mm | 1112 / 2538 / 2334 | 05-01-2024

**UNIC**  
STAINLESS CYLINDER

## Typeoversigt

Type	1112	2538	2334

Beslag og tilbehør					

# Festo kompatibel cylinder

Ø32 mm - Ø63 mm | 1112 / 2538 / 2334 | 05-01-2024

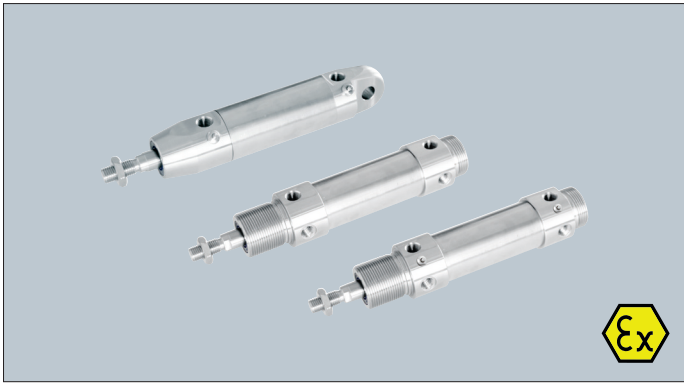

## Specifikationer

Diameter	Ø32 mm - Ø63 mm
Erstatter:	CRDSNU / CRDSW
Arbejdsstryk	3 bar til 10 bar
Temperatur	-20°C til +80°C
Standard slaglængder	10-500 mm

## Materialer

Stempelstang, Beslag, Cylinderrør, Endegavle	AISI 304 / (EN 1.4301)
Stempel:	POM
Skraber:	Nitrilgummi / Polyuretan
O-ringe:	Viton

## Standard

Magnet for aftastning
Justerbar endeslagsdæmpning

## Typer

1112	Med svingøje
2538	Med gevind (Udem bremse)
2334	Med gevind (Med bremse)

## Optioner

AISI 316L (EN 1.4404)
Cylinder med øget kemikalieresistens
Varmebestandig cylinder op til +150°C
Kundetilpasset efter ønske
Renovering / Rep.sæt (Side 38)

## Bestillingsnøgle

Ø40 x 150 mm = **U040 0150 2538**

**Varmebestandig** cylinder H  
(Gælder ikke 1112):

**Kemikalieresistent** cylinder C  
Cylinder med **PTFE** afstryger: P

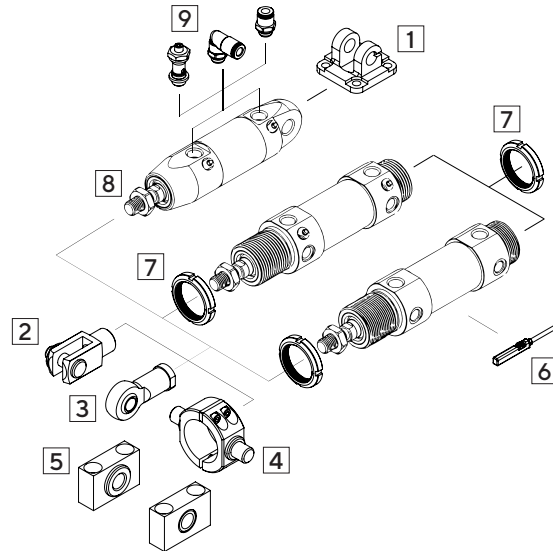

## Tilbehør

Side ->

1	Smalt gaffelbeslag	45
2	Stempelstangsgaffel	40
3	Sfærisk ledøje	40
4	Central drejebeslag	46
5	Lejebuk for drejebeslag	47
6	Reedsensor	48
7	Halsmøtrik	38
8	Stempelstangsmøtrik	39
9	Fittings	49

## Teoretiske cylinderkræfter opgivet i Newton

Cyl.Ø	st/stØ	Stempelareal cm <sup>2</sup>		3 bar		4 bar		5 bar			
		•	◦	•	◦	•	◦	•	◦		
32	12	8,0	6,9	212	182	282	243	352	304		
40	16	12,6	10,6	333	282	444	373	554	466		
50	20	19,6	16,5	517	436	690	581	862	726		
63	20	31,1	28,0	824	739	1098	986	1373	1232		
		6 bar		7 bar		8 bar		9 bar		10 bar	
		•	◦	•	◦	•	◦	•	◦	•	◦
	422	364	493	425	563	486	634	546	704	607	
	665	560	776	653	887	746	998	840	1109	933	
	1035	871	1207	1016	1380	1162	1552	1307	1725	1452	
	1647	1478	1923	1725	2196	1971	2471	2218	2746	2464	



# Festo kompatibel

Teknisk data | 05-01-2024

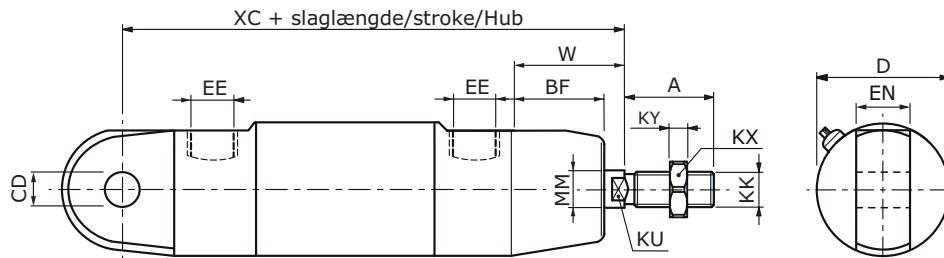

1112

Ø	A	BF	CD	D	EE	EN	KK	KU	KX	KY	MM	W	XC
32	22	20	Ø10	33,6	G1/8"	14	M10x1,25	10	17	5	Ø12	34	118
40	24	22	Ø12	41,6	G1/4"	16	M12x1,25	13	19	6	Ø16	39	140
50	32	29	Ø16	52,4	G1/4"	21	M16x1,50	17	24	6	Ø20	44	147
63	32	29	Ø16	65,4	G3/8"	21	M16x1,50	17	24	6	Ø20	44	156

\*Bemærk. Alle mål er med 0,0 mm slaglængde.

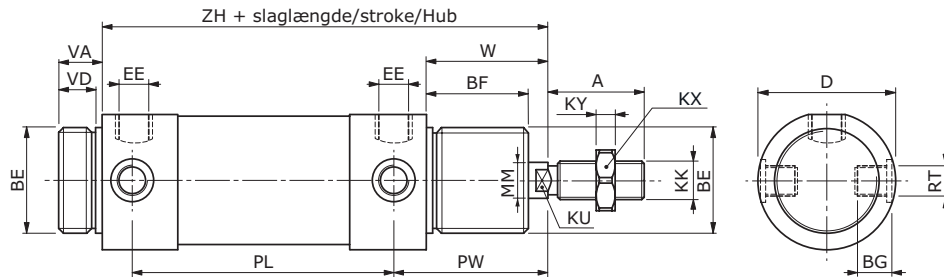

2538/2334

Ø	A	BE	BF	BG	D	EE	KK	KU	KX	KY	MM	PL	PW	RT	VA	VD	W	ZH
32	22	M30x1,50	30	6,6	38	G1/8"	M10x1,25	10	17	5	Ø12	78	47	M8x1,00	14	12	38	134
40	24	M38x1,50	35	9,6	49	G1/4"	M12x1,25	13	19	6	Ø16	89	57	M10x1,00	16	13	45	158
50	32	M45x1,50	38	12,6	59	G1/4"	M16x1,50	17	24	6	Ø20	96	62	M12x1,50	18	15	50	170
63	32	M45x1,50	38	15,5	70	G3/8"	M16x1,50	17	24	6	Ø20	98	63	M14x1,50	18	15	50	174

\*Bemærk. Alle mål er med 0,0 mm slaglængde.

# Adapter A1 og A2

Ø25 mm - Ø125 mm | AISI 304 (EN 1.4301) \*Kan leveres i AISI 316L (EN 1.4404) | Skraber i PTFE | 05-01-2024

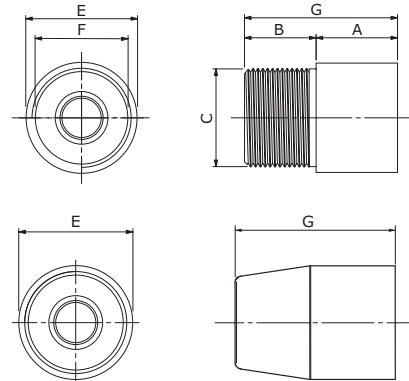
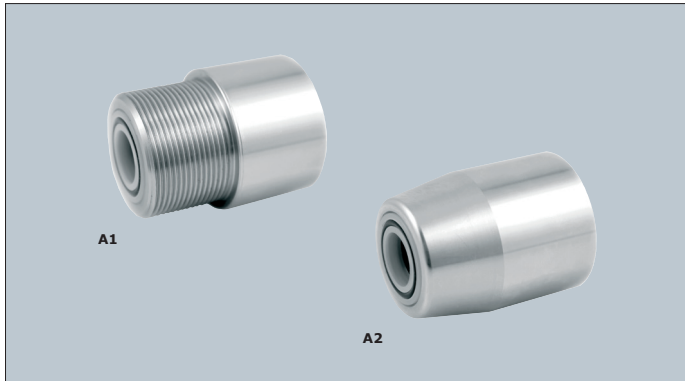
**UNIC**  
 STAINLESS CYLINDER

Ø	A	B	C	E	F	G	kg	Rep.sæt	Varenummer (A1)	Varenummer (A2)
32	25	20	M30x1,5	33,6	M30x1,5	47	0,15	U1903242-P	U1903248-48	U1903249-48
40	28	22	M36x1,5	41,6	M36x1,5	50	0,25	U1904042-P	U1904048-48	U1904049-48
50	34	29	M42x1,5	52,4	M42x1,5	63	0,40	U1905042-P	U1905048-48	U1905049-48
63	34	29	M42x1,5	65,4	M42x1,5	63	0,55	U1906342-P	U1906348-48	U1906349-48
80	40	35	M55x1,50	86	M55x1,5	75	1,00	U1908042-P	U1908048-48	U1908049-48
100	43	38	M55x1,50	106	M55x1,5	81	1,90	U1910042-P	U1910048-48	U1910049-48
125	55,0	50	M60x2,0	132	M60x2,0	105	4,50	U1912542-P	U1912548-48	U1912549-48

# Halsmøtrik

Ø32 mm - Ø63 mm | AISI 304 (EN 1.4301) | (CRDSW) | 05-01-2024

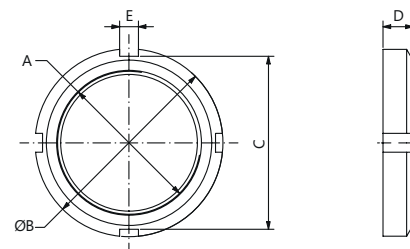

Ø	A	C	D	E	ØB	kg	Varenummer
32	M30x1,5	45	7	5	45	0,030	U1903201
40	M38x1,5	46	8	5	50	0,055	U1904001
50/63	M45x2,0	52	9	6	58	0,110	U1905901



# Halsmøtrik

Ø12 mm - Ø125 mm | AISI 304 (EN 1.4301) | 05-01-2024

**UNIC**  
STAINLESS CYLINDER

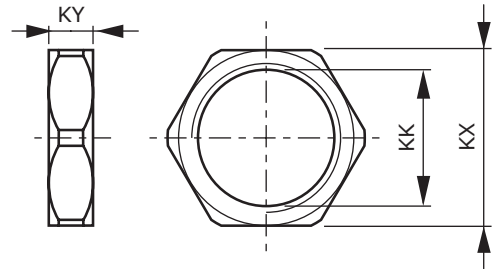
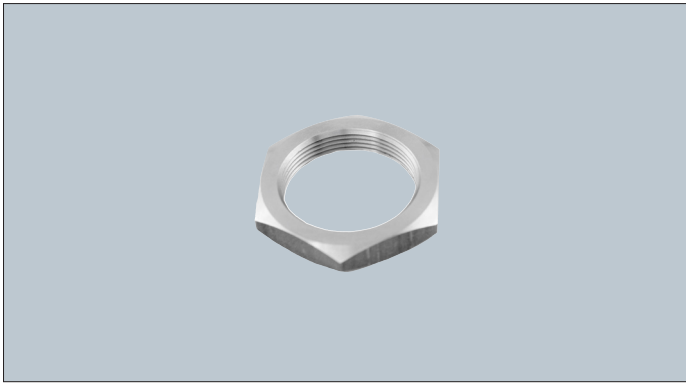

Ø	KK	KX	KY	kg	Varenummer
12/16	M16x1,5	24	8	0,018	<b>U1901402</b>
20/25	M22x1,5	27	8	0,018	<b>U1902502</b>
32	M30x1,5	36	8	0,030	<b>U1903202</b>
40	M36x1,5	46	8	0,055	<b>U1904002</b>
50/63	M42x1,5	55	8	0,110	<b>U1905002</b>
80/100	M55x1,5	70	12	0,180	<b>U1909002</b>
125	M60x2,0	90	12	0,500	<b>U1912502</b>

# Stempelstangsmøtrik

Ø12 mm - Ø125 mm | AISI 304 (EN 1.4301) | 05-01-2024

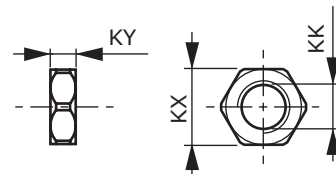
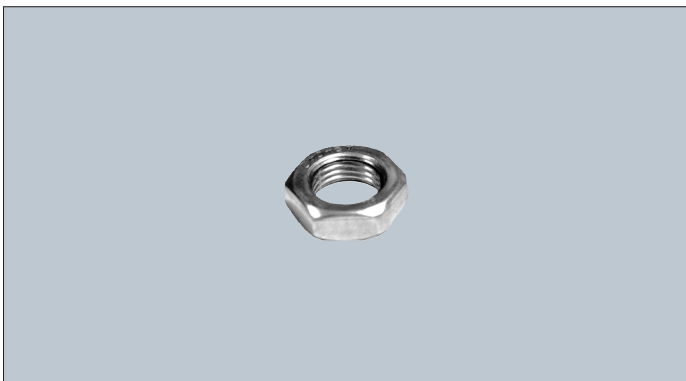

Ø	KK	KX	KY	kg	Varenummer
12/16	M6	10	3,5	0,005	<b>U1901430</b>
20	M8	13	4,0	0,008	<b>U1902030</b>
25/32	M10x1,25	17	5,0	0,010	<b>U1903030</b>
40	M12x1,25	19	6,0	0,012	<b>U1904030</b>
50/63	M16x1,50	24	8,0	0,017	<b>U1905930</b>
80/100	M20x1,50	30	9,0	0,030	<b>U1909030</b>
125	M27x2,00	41	13,5	0,108	<b>U1912530</b>

## Sfærisk ledøje

Ø12 mm - Ø125 mm | DIN/ISO 8139 | AISI 304 / AISI 303 / AISI 440C (EN 1.4301 / 1.4305 / 1.4125) | 05-01-2024

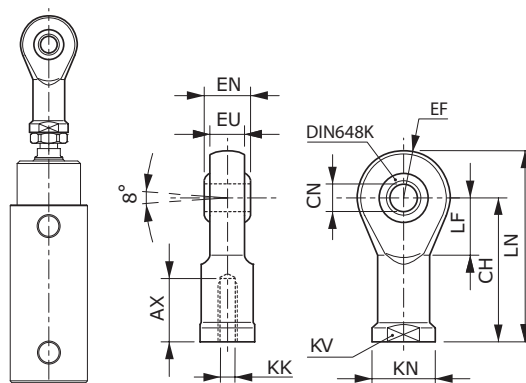
**UNIC**  
 STAINLESS CYLINDER

Ø	AX	CH	CN	EF	EN	EU	KK	KN	KV	LF	LN	kg	Varenummer
12/16	12	30	Ø6	10	9	6,75	M6	13	11	11	40	0,020	<b>U1901427</b>
20	16	36	Ø8	12	12	9	M8	16	14	13	48	0,045	<b>U1902027</b>
25/32	20	43	Ø10	14	14	10,50	M10x1,25	19	17	15	57	0,061	<b>U1903027</b>
40	22	50	Ø12	16	16	12	M12x1,25	22	19	17	66	0,092	<b>U1904027</b>
50/63	28	64	Ø16	21	21	15	M16x1,50	27	22	22	85	0,179	<b>U1905927</b>
80/100	33	77	Ø20	25	25	18	M20x1,50	34	30	26	102	0,330	<b>U1909027</b>
125	51	110	Ø30	35	37	25	M27x2,00	50	41	36	145	1,166	<b>U1912527</b>

## Stempelstangsgaffel

Ø12 mm - Ø125 mm | DIN/ISO 8140 | AISI 303 (EN 1.4305) | 05-01-2024

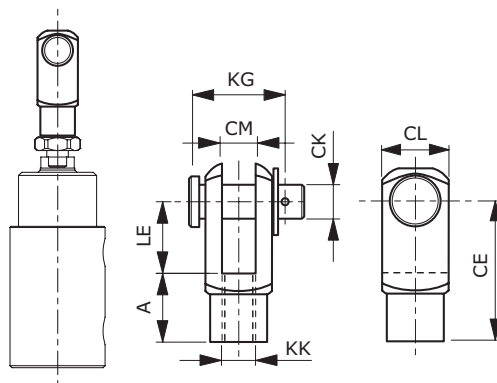

Ø	A	CE	CK	CL	CM	KG	KK	LE	kg	Varenummer
12/16	12	24	6	12	6	16	M6	12	0,025	<b>U1901423</b>
20	16	32	8	16	8	22	M8	16	0,049	<b>U1902023</b>
25/32	20	40	10	20	10	26	M10x1,25	20	0,095	<b>U1903023</b>
40	24	48	12	24	12	31,50	M12x1,25	24	0,160	<b>U1904023</b>
50/63	32	64	16	32	16	40,50	M16x1,50	32	0,355	<b>U1905923</b>
80/100	40	80	20	40	20	50	M20x1,50	40	0,726	<b>U1909023</b>
125	56	110	30	55	30	63	M27x2,00	54	1,602	<b>U1912523</b>



# Fodbeslag

Ø12 mm - Ø25 mm | DIN/ISO 6432 | AISI 304 (EN 1.4301) | 05-01-2024

**UNIC**  
STAINLESS CYLINDER

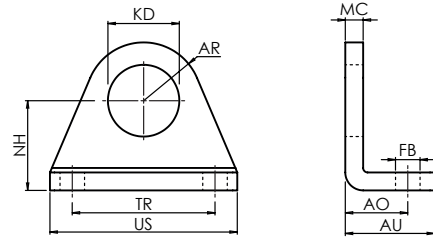

Ø	AO	AR	AU	FB	KD	MC	NH	TR	US	kg	Varenummer
12	14	13	20	Ø5,50	Ø16,10	3	20	32	42	0,042	<b>U1901407</b>
16	14	13	20	Ø5,50	Ø16,10	3	20	32	42	0,042	<b>U1901407</b>
20	17	20	25	Ø6,60	Ø22,10	3	25	40	54	0,090	<b>U1902307</b>
25	17	20	25	Ø6,60	Ø22,10	3	25	40	54	0,090	<b>U1902307</b>

# Drejebeslag

Ø12 mm - Ø25 mm | DIN/ISO 6432 | AISI 304 (EN 1.4301) | 05-01-2024

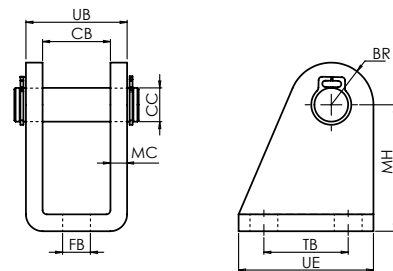

Ø	BR	CB	CC	FB	MC	MH	TB	UB	UE	kg	Varenummer
12	7	12,10	Ø6	Ø5,50	3	27	15	18,10	25	0,034	<b>U1901403</b>
16	7	12,10	Ø6	Ø5,50	3	27	15	18,10	25	0,034	<b>U1901403</b>
20	10	16,10	Ø8	Ø6,60	4	30	20	24,10	32	0,078	<b>U1902303</b>
25	10	16,10	Ø8	Ø6,60	4	30	20	24,10	32	0,078	<b>U1902303</b>

## Drejebeslag

Ø32 mm - Ø125 mm | DIN/ISO 15552 | AISI 304 (EN 1.4301) | Inkl. montageskruer | 05-01-2024

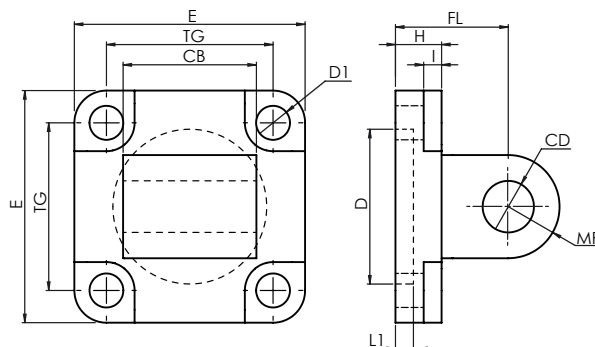
**UNIC**  
 STAINLESS CYLINDER

Ø	CB	CD	D	D1	E	FL	H	I	L1	MR	TG	kg	Varenummer
32	26	Ø10	Ø30	Ø6,60	45	22	9	3,5	5	10	32,50	0,16	U1903212E
40	28	Ø12	Ø35	Ø6,60	55	25	9	3,5	5	12	38	0,22	U1904012E
50	32	Ø12	Ø40	Ø9	65	27	11	4,5	5	12	46,50	0,37	U1905012E
63	40	Ø16	Ø45	Ø9	75	32	11	4,5	5	16	56,50	0,63	U1906312E
80	50	Ø16	Ø45	Ø11	95	36	14	4	5	16	72	1,2	U1908012E
100	60	Ø20	Ø55	Ø11	115	41	14	4	5	20	89	2	U1910012E
125	70	Ø25	Ø60	Ø14	140	50	20	10	7	25	110	3,5	U1912512E

## Drejebeslag 90°

Ø32 mm - Ø125 mm | DIN/ISO 15552 | AISI 304 (EN 1.4301) | Inkl. montageskruer | 05-01-2024

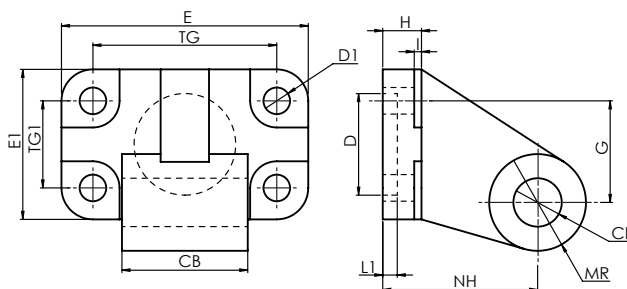

Ø	CB	CD	D	D1	E	E1	G	I	H	L1	MR	NH	TG	TG1	kg	Varenummer
32	26	Ø10	Ø21	Ø6,60	51	31	21	1,5	8	3	10	32	38	18	0,16	U1903213E
40	28	Ø12	Ø21	Ø6,60	54	35	24	1,5	10	3	11	36	41	22	0,25	U1904013E
50	32	Ø12	Ø21	Ø9	65	45	33	1,5	12	3	13	45	50	30	0,45	U1905013E
63	40	Ø16	Ø21	Ø9	67	50	37	1,5	12	3	15	50	52	35	0,60	U1906313E
80	50	Ø16	Ø21	Ø11	86	60	47	2,5	14	3	15	63	66	40	1	U1908013E
100	60	Ø20	Ø21	Ø11	96	70	55	2,5	15	3	18	71	76	50	1,5	U1910013E
125	70	Ø25	Ø21	Ø14	124	90	70	3	20	3	22	90	94	60	3,1	U1912513E





# Gaffelbeslag

**UNIC**  
STAINLESS CYLINDER

Ø32 mm - Ø125 mm | DIN/ISO 15552 | AISI 304 (EN 1.4301) | Inkl. montageskruer | 05-01-2024

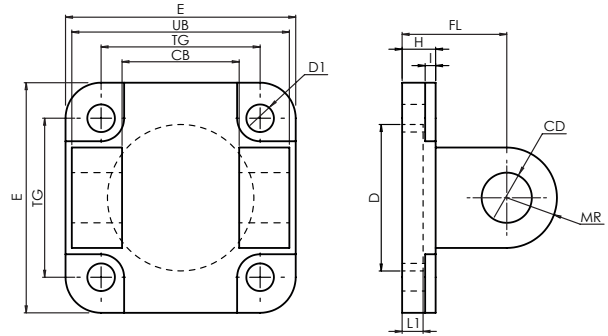
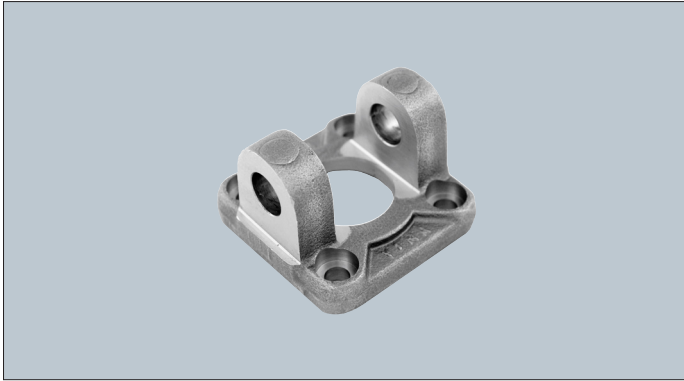

Cyl	CB	CD	D	D1	E	FL	I	H	L1	MR	TG	UB	kg	Varenummer
32	26	Ø10	Ø30	Ø6,60	45	22	2,5	8	5	10	32,50	45	0,1	<b>U1903214E</b>
40	28	Ø12	Ø35	Ø6,60	55	25	2,5	8	5	12	38	52	0,2	<b>U1904014E</b>
50	32	Ø12	Ø40	Ø9	65	27	3,5	10	5	12	46,50	60	0,3	<b>U1905014E</b>
63	40	Ø16	Ø45	Ø9	75	32	3,5	10	5	15	56,50	70	0,5	<b>U1906314E</b>
80	50	Ø16	Ø45	Ø11	95	36	3	13	-	15	72	90	0,9	<b>U1908014E</b>
100	60	Ø20	Ø55	Ø11	115	41	3	13	-	20	89	110	1,5	<b>U1910014E</b>
125	70	Ø25	Ø60	Ø14	140	50	6	16	-	25	110	130	2,9	<b>U1912514E</b>

# Bolt for gaffelbeslag

Ø32 mm - Ø125 mm | DIN/ISO 15552 | AISI 304 (EN 1.4301) | 05-01-2024

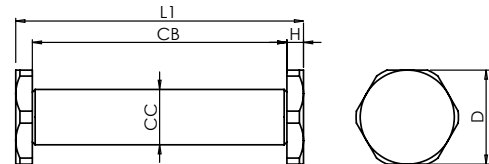

Cyl.	CB	CC	D	H	L1	kg	Varenummer
32	46	10	18,50	3	53	0,04	<b>U1903215</b>
40	53	12	18,50	3	59	0,05	<b>U1904015</b>
50	61	12	18,50	3	63	0,06	<b>U1905015</b>
63	71	16	26	4	78	0,15	<b>U1906315</b>
80	91	16	26	4	98	0,2	<b>U1908015</b>
100	11	20	34	5	120	0,3	<b>U1910015</b>
125	132	25	34	5	140	0,5	<b>U1912515</b>

## Lige drejebeslag

Ø80 mm - Ø125 mm | DIN/ISO 15552 | AISI 304 (EN 1.4301) | Inkl. montageskruer | 05-01-2024

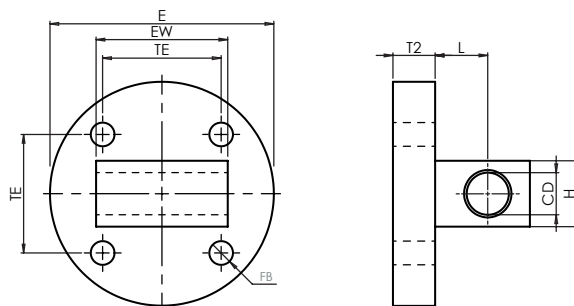
**UNIC**  
 STAINLESS CYLINDER

Cyl.	CD	E	EW	FB	H	L min.	TE	T2	kg	Varenummer
80	Ø16	85	50	Ø9	25	20	45	16	0,9	<b>U1908004</b>
100	Ø20	105	60	Ø10	30	25	55	16	1,6	<b>U1910004</b>
125	Ø20	130	70	Ø14	40	30	70	20	2,9	<b>U1912504</b>

## Beslag med ledøje

Ø32 mm - Ø125 mm | DIN/ISO 15552 | AISI 316L (EN 1.4404) | Inkl. montageskruer | 05-01-2024

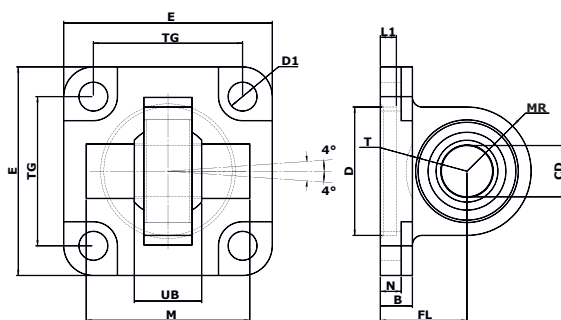

Cyl.	B	CD	D	D1	E	FL	L1	N	M	MR	T	TG	UB	kg	Varenummer
32	8	Ø10	Ø30	Ø6,60	45	22	5	5,5	-	15	-	32,50	14	0,1	<b>U1903219E</b>
40	8	Ø12	Ø35	Ø6,60	55	25	5	5,5	-	18	-	38	16	0,2	<b>U1904019E</b>
50	10	Ø16	Ø40	Ø9	65	27	5	6,5	51	20	19	46,50	21	0,3	<b>U1905019E</b>
63	10	Ø16	Ø45	Ø9	75	32	5	6,5	-	23	-	56,50	21	0,5	<b>U1906319E</b>
80	13	Ø20	Ø45	Ø11	95	36	5	10	70	27	24	72	25	1,0	<b>U1908019E</b>
100	13	Ø20	Ø55	Ø11	115	41	5	10	-	30	-	89	25	1,5	<b>U1910019E</b>
125	16	Ø30	Ø60	Ø13,50	140	50	7	10	102	40	35	110	37	3,0	<b>U1912519E</b>



# Smalt gaffelbeslag

**UNIC**  
STAINLESS CYLINDER

Ø32 mm - Ø125 mm | DIN/ISO 15552 | AISI 316L (EN 1.4404) | Inkl. montageskruer | 05-01-2024

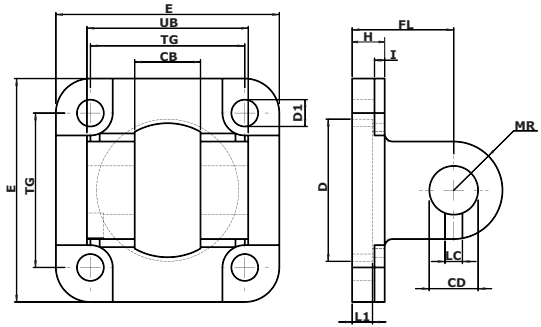

Cyl.	CB	CD	D	D1	E	FL	I	H	L1	MR	TG	UB	LC	kg	Varenummer
32	14	Ø10	Ø30	Ø6,60	45	22	2,5	8	5	10	32,50	34	3,3	0,1	<b>U1903210E</b>
40	16	Ø12	Ø35	Ø6,60	55	25	2,5	8	5	12	38	40	4,3	0,2	<b>U1904010E</b>
50	21	Ø12	Ø40	Ø9	65	27	3,5	10	5	12	46,50	45	4,3	0,3	<b>U1905010E</b>
63	21	Ø16	Ø45	Ø9	75	32	3,5	10	5	15	56,50	51	4,3	0,5	<b>U1906310E</b>
80	25	Ø16	Ø45	Ø11	95	36	3	13	-	15	72	65	4,3	1,0	<b>U1908010E</b>
100	25	Ø20	Ø55	Ø11	115	41	3	13	-	20	89	75	4,3	1,6	<b>U1910010E</b>
125	37	Ø30	Ø60	Ø13,50	140	50	6	16	-	30	110	97	6,3	3,2	<b>U1912510E</b>

# Drejesikret bolt - til smalt gaffelbeslag

Ø32 mm - Ø125 mm | DIN/ISO 15552 | AISI 316L (EN 1.4404) | Inkl. låsering | 05-01-2024

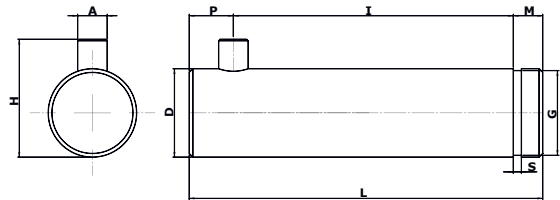

Cyl.	A	D	G	H	I	L	M	P	S	kg	Varenummer
32	3	10	9,6	14	32,5	41	4	4,5	1,1	0,03	<b>U1903211E</b>
40	4	12	11,5	16	38	48	4	6	1,1	0,05	<b>U1904011E</b>
50	4	16	15,2	20	43	54	5	6	1,1	0,1	<b>U1905011E</b>
63	4	16	15,2	20	49	60	5	6	1,1	0,1	<b>U1906311E</b>
80	4	20	19	24	63	75	6	6	1,3	0,2	<b>U1908011E</b>
100	4	20	19	24	73	85	6	6	1,3	0,2	<b>U1910011E</b>
125	6	30	28,6	36	94	110	7	9	1,6	0,6	<b>U1912511E</b>

## Bolt for baggavl nr. 18

Ø32 mm - Ø125 mm | DIN/ISO 15552 | AISI 304 (EN 1.4301) | 05-01-2024

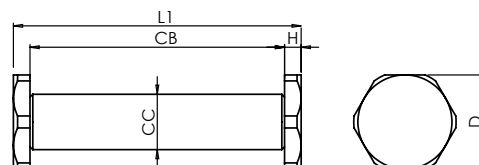
**UNIC**  
 STAINLESS CYLINDER

Cyl.	CB	CC	D	H	L1	kg	Varenummer
32	36	10	18,50	3	42	0,03	U1903205
40	46	12	18,50	3	52	0,05	U1904005
50	51	12	18,50	3	57	0,06	U1905005
63	61	16	26	4	69	0,12	U1906305
80	71	16	26	4	79	0,14	U1908005
100	81	20	34	5	91	0,26	U1910005
125	101	25	34	5	111	0,45	U1912505

## Central drejebeslag

Ø32 mm - Ø125 mm | DIN/ISO 15552 | AISI 304 (EN 1.4301) | 05-01-2024

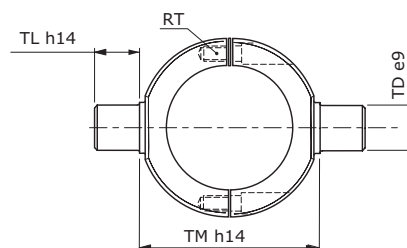

Cyl.	L1	RT	TD	TL	TM	kg	Varenummer
32	25	M5	12	18	50	0,20	U1903217
40	28	M5	16	21	63	0,37	U1904017
50	28	M5	16	21	75	0,37	U1905017
63	36	M5	20	23	90	0,76	U1906317
80	36	M6	20	23	110	0,90	U1908017
100	48	M6	25	28,50	132	1,40	U1910017
125	50	M6	25	28,50	160	1,70	U1912517



# Lejebuk for drejebeslag – sæt

Ø32 mm - Ø125 mm | DIN/ISO 15552 | AISI 304 (EN 1.4301) | 05-01-2024

**UNIC**  
STAINLESS CYLINDER

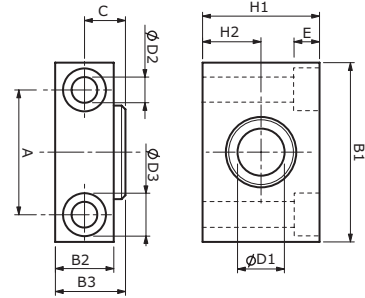
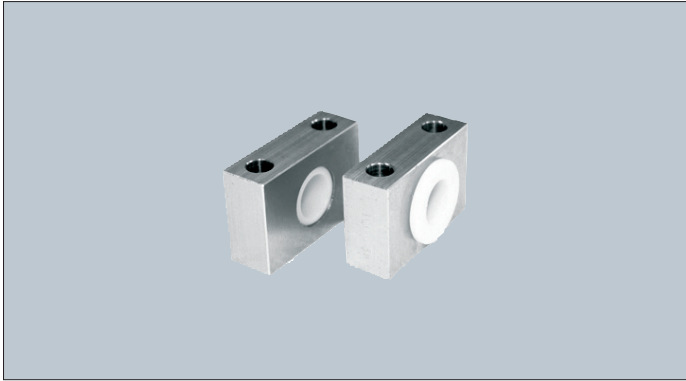

Cyl.	A	B1	B2	B3	C	D1	D2	D3	E	H1	H2	kg	Varenummer
32	32	46	15	18	11	12	6,60	11	7	30	15	0,25	<b>U1903216</b>
40	36	55	18	21	12	16	9	15	9	36	18	0,40	<b>U1904516</b>
50	36	55	18	21	12	16	9	15	9	36	18	0,40	<b>U1904516</b>
63	42	65	20	23	13	20	11	18	11	40	20	0,50	<b>U1907016</b>
80	42	65	20	23	13	20	11	18	11	40	20	0,50	<b>U1907016</b>
100	50	75	25	28,50	16	25	14	20	13	50	25	0,99	<b>U1911016</b>
125	50	75	25	28,50	16	25	14	20	13	50	25	0,99	<b>U1911016</b>

# Superflex nylonslange

Ø4 mm - Ø12 mm | PA (Natur) / PVDF (Teflon) | 05-01-2024

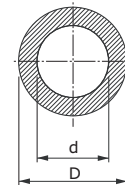

D	d	Rullelængde	Varenummer - PA (Natur)	Varenummer - PVDF (Teflon)
Ø4	Ø2	100 meter	<b>PA0501-4/2</b>	<b>HN-PVDF-4/2</b>
Ø6	Ø4	100 meter	<b>PA0501-6/4</b>	<b>HN-PVDF-6/4</b>
Ø8	Ø6	100 meter	<b>PA0501-8/6</b>	<b>HN-PVDF-8/6</b>
Ø10	Ø8	100 meter	<b>PA0501-10/8</b>	<b>HN-PVDF-10/8</b>
Ø12	Ø9	100 meter	<b>PA0501-12/9</b>	<b>HN-PVDF-12/9</b>

# Reedsensorer

Kunststof | IP67 | 05-01-2024

**UNIC**  
STAINLESS CYLINDER

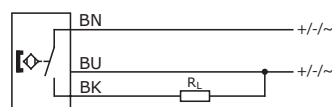

**Ledningsfarver**

BN=brun / BK=sort / BU=blå

Leder	Spænding	Strøm (max)	Kabel	Varenummer
3	10 - 30V DC	100 mA DC	3 m PUR	<b>0 830 100 629</b>
3	10 - 30V DC	100 mA DC	5 m PUR	<b>0 830 100 630</b>

# Beslag for reedkontakt

Ø12 mm - Ø125 mm | AISI 304 (EN 1.4301) | 05-01-2024

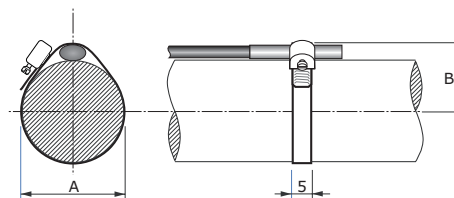

Cyl.	A	B	Varenummer
12	15	11	<b>U1900312</b>
16	19	13	<b>U1900313</b>
20	23	15	<b>U1900314</b>
25	29	18	<b>U1900315</b>
32	36	21	<b>U1900316</b>
40	44	25	<b>U1900317</b>
50	55	30	<b>U1900318</b>
63	68	37	<b>U1900319</b>
80	86	47	<b>U1900320</b>
100	106	57	<b>U1900321</b>
125	131	70	<b>U1900322</b>







# Rustfrie fittings

**UNIC**  
STAINLESS CYLINDER

Viton o-ring | AISI 316 (EN 1.4404) | 05-01-2024

Vinkel, vridbar, udv. gevind				Vinkel	
Gevind	Slange	Varenummer		Slange	Varenummer
M5	Ø4	<b>MX 16 04 M5</b>	Ø4	<b>MX 28 04 04</b>	
	Ø4	<b>MX 16 04 18</b>	Ø6	<b>MX 28 06 06</b>	
G 1/8"	Ø6	<b>MX 16 06 18</b>	Ø8	<b>MX 28 08 08</b>	
	Ø8	<b>MX 16 08 18</b>	Ø10	<b>MX 28 10 10</b>	
G 1/4"	Ø6	<b>MX 16 06 14</b>	Ø12	<b>MX 28 12 12</b>	
	Ø8	<b>MX 16 08 14</b>			

  

T-stykker, vridbar, udv. gevind				T-stykke	
Gevind	Slange	Varenummer		Slange	Varenummer
M5	Ø4	<b>MX 21 04 M5</b>	Ø4	<b>MX 29 04 04</b>	
	Ø4	<b>MX 21 04 18</b>	Ø6	<b>MX 29 06 06</b>	
G 1/8"	Ø6	<b>MX 21 06 18</b>	Ø8	<b>MX 29 08 08</b>	
	Ø8	<b>MX 21 08 18</b>	Ø10	<b>MX 29 10 10</b>	
G 1/4"	Ø6	<b>MX 21 06 14</b>	Ø12	<b>MX 29 12 12</b>	
	Ø8	<b>MX 21 08 14</b>			

  

Kontradrøventil, udv. gevind			Banjoring		
Gevind	Varenummer		Gevind	Slange	Varenummer
G 1/8"	<b>VX 25 04 06</b>		G 1/8"	Ø4	<b>MX 35 04 18</b>
G 1/4"	<b>VX 25 06 08</b>			Ø6	<b>MX 35 06 18</b>
			G 1/4"	Ø8	<b>MX 35 08 18</b>
				Ø6	<b>MX 35 06 14</b>
				Ø8	<b>MX 35 08 14</b>

  

Lige union, udv. gevind				Reduktion		
Gevind	Slange	Varenummer		Slange A	Slange B	Varenummer
M5	Ø4	<b>MX 12 04 M5</b>	Ø4	Ø6	<b>MX 25 04 06</b>	
	Ø4	<b>MX 12 04 18</b>	Ø6	Ø8	<b>MX 25 06 08</b>	
G 1/8"	Ø6	<b>MX 12 06 18</b>	Ø8	Ø10	<b>MX 25 08 10</b>	
	Ø8	<b>MX 12 08 18</b>				
1/4"	Ø6	<b>MX 12 06 14</b>				
	Ø8	<b>MX 12 08 14</b>				

Skotforskruing				Samlestykke		
Gevind	Slange	Varenummer		Slange A	Slange B	Varenummer
M12x1	Ø4	<b>MX 27 04 04</b>	Ø4	Ø4	<b>MX 26 04 04</b>	
M14x1	Ø6	<b>MX 27 06 06</b>	Ø6	Ø6	<b>MX 26 06 06</b>	
M16x1	Ø8	<b>MX 27 08 08</b>	Ø8	Ø8	<b>MX 26 08 08</b>	
M18x1	Ø10	<b>MX 27 10 10</b>	Ø10	Ø10	<b>MX 26 10 10</b>	
M20x1	Ø12	<b>MX 27 12 12</b>	Ø12	Ø12	<b>MX 26 12 12</b>	





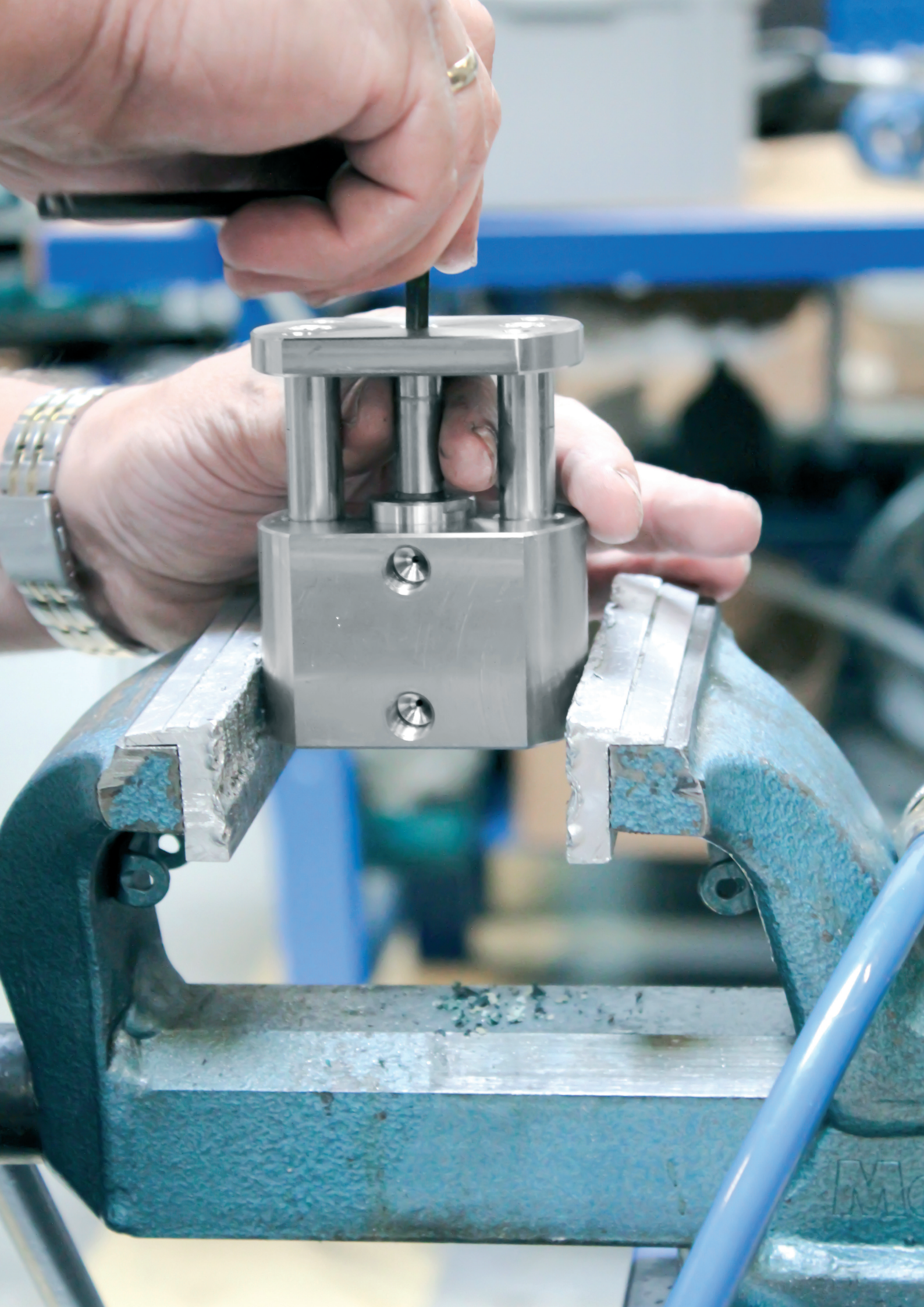



# Specialcylindre

**UNIC**  
STAINLESS CYLINDER



I dag stilles der større og større krav til omstilling og fleksibilitet af mennesker og maskiner indenfor automation og processteknik.

Teknologien har skabt mulighed for at tilbyde individuelle tilpasninger af produktionsudstyret til de enkelte virksomheders ønsker og behov.

Hos HNC kan du få fremstillet cylindre, som netop matcher dine behov og dine maskiner, hvilket sikrer, at dine maskineanlæg hurtigt kan omstilles til nye produktioner og dermed altid være på forkant med, hvad markedet efterspørger.

Vores produktsortiment giver mulighed for både individuelle tilpasninger såvel som standardløsninger, afstemt efter kundens præcise behov, så unødige udgifter til overdimensioneret udstyr undgås.

Specialtilpassede løsninger kan bl.a. være:

- Slaglængde
- Diameter
- Specielle for- og bagfavle
- Stålkvalitet
- Forlænget stempelstang
- Med og uden fjeder og bremse
- Kemi- og varmeresistent

Leveringstiden er kort både indenfor standardløsninger som indenfor kundetilpassede løsninger. Maskinenedbrud er kostbare, derfor er HNC's leveringssikkerhed din driftssikkerhed.

## 2D / 3D tegninger

I vores design- og udviklingsafdeling tegnes cylindrene både i 2D og 3D, og vi kan naturligvis fremstille tegninger efter vores kunders ønsker.

Vores kunder har mulighed for at få tilsendt 3D filer, så det vil være muligt at indsætte disse direkte i kundernes egne 3D konstruktioner.

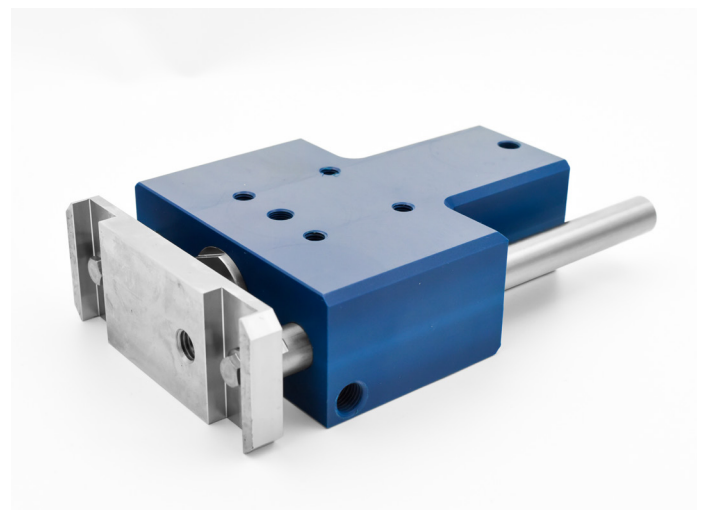

# Reparationsset for cylindre

05-01-2024



## Standard cylinder DIN/ISO 6432 uden bremse Ø12 mm - Ø25 mm | Rep.sæt

Ø	Standard	Varme	Kemikalie
12	U1901231	U1901231-H	U1901231-C
16	U1901631	U1901631-H	U1901631-C
20	U1902031	U1902031-H	U1902031-C
25	U1902531	U1902531-H	U1902531-C

## Standard cylinder DIN/ISO 6432 med bremse Ø12 mm - Ø25 mm | Rep.sæt

Ø	Standard	Varme	Kemikalie
12	-	-	-
16	-	-	-
20	U1902032	U1902032-H	U1902032-C
25	U1902532	U1902532-H	U1902532-C

## Standard cylinder DIN/ISO 15552 Ø32 mm - Ø125 mm | Rep.sæt

Ø	Standard	Varme	Kemikalie	PTFE
32	U1903232	U1903232-H	U1903232-C	U1903232-P
40	U1904032	U1904032-H	U1904032-C	U1904032-P
50	U1905032	U1905032-H	U1905032-C	U1905032-P
63	U1906332	U1906332-H	U1906332-C	U1906332-P
80	U1908032	U1908032-H	U1908032-C	U1908032-P
100	U1910032	U1910032-H	U1910032-C	U1910032-P
125	U1912532	U1912532-H	U1912532-C	U1912532-P

## Standard cylinder DIN/ISO 15552 Ø32 mm - Ø100 mm | Rep.sæt | 2130

Ø	Standard
32	U1903237
40	U1904037
50	U1905037
63	U1906337
80	U1908037
100	U1910037

## Kompaktcylinder ISO 21287 Ø20 mm - Ø100 mm | Rep.sæt | 5150

Ø	Standard
20	KIT XDM020 GS
25	KIT XDM025 GS
32	KIT XDM032 GS
40	KIT XDM040 GS
50	KIT XDM050 GS
63	KIT XDM063 GS
80	KIT XDM080 GS
100	KIT XDM100 GS

## Festo kompatibel cylinder Ø32 mm - Ø63 mm | Rep.sæt | 2538 / 2334

Ø	Standard	Varme	Kemikalie	PTFE
32	U1903232	U1903232-H	U1903232-C	U1903232-P
40	U1904032	U1904032-H	U1904032-C	U1904032-P
50	U1905032	U1905032-H	U1905032-C	U1905032-P
63	U1906332	U1906332-H	U1906332-C	U1906332-P

## Festo kompatibel cylinder Ø32 mm - Ø63 mm | Rep.sæt | 1112

Ø	Standard	Kemikalie	PTFE
32	U1903233	U1903233-C	U1903233-P
40	U1904033	U1904033-C	U1904033-P
50	U1905033	U1905033-C	U1905033-P
63	U1906333	U1906333-C	U1906333-P



# Cylinderkræfter og luftforbrug

05-01-2024

## Teoretiske cylinderkræfter opgivet i Newton

Ø	st/st Ø	Stempelareal cm <sup>2</sup>		3 bar		4 bar		5 bar		6 bar		7 bar		8 bar		9 bar		10 bar	
		•	◦	•	◦	•	◦	•	◦	•	◦	•	◦	•	◦	•	◦	•	◦
12	6	1,1	0,8	29	22	39	30	48	37	58	45	68	52	77	60	87	67	97	75
16	6	2,0	1,7	53	46	70	61	88	76	106	91	123	107	141	122	158	137	176	152
20	8	3,1	2,6	82	69	109	92	136	114	164	137	191	160	218	183	246	206	273	229
25	10	4,9	4,1	129	108	172	144	216	180	259	216	302	253	345	289	388	325	421	361
32	12	8,0	6,9	212	182	282	243	352	304	422	364	493	425	563	486	634	546	704	607
40	16	12,6	10,6	333	282	444	373	554	466	665	560	776	653	887	746	998	840	1109	933
50	20	19,6	16,5	517	436	690	581	862	726	1035	871	1207	1016	1380	1162	1552	1307	1725	1452
63	20	31,1	28,0	824	739	1098	986	1373	1232	1647	1478	1923	1725	2196	1971	2471	2218	2746	2464
80	25	50,3	45,3	1328	1199	1771	1598	2213	1998	2656	2397	3098	2797	3541	3196	3984	3596	4426	3995
100	25	78,5	73,6	2072	1943	2763	2591	3454	3238	4145	3886	4836	4534	5526	5181	6217	5829	6908	6477
125	32	122,7	114,6	3239	3028	4319	4037	5399	5047	6479	6056	7558	7066	8638	8075	9718	9084	10798	10094

• = Cylinder i plusretning ◦ = Cylinder i minusretning

## Luftforbrug liter/dobbeltslag

Ø	st/st Ø	Slaglængde mm	3 bar	4 bar	5 bar	6 bar	7 bar	8 bar	9 bar	10 bar
12	6	100	0,08	0,10	0,12	0,14	0,16	0,18	0,20	0,22
16	6	100	0,15	0,19	0,22	0,26	0,30	0,33	0,37	0,41
20	8	100	0,23	0,29	0,34	0,40	0,46	0,51	0,57	0,63
25	10	100	0,36	0,45	0,54	0,63	0,71	0,80	0,89	1,00
32	12	100	0,59	0,74	0,89	1,00	1,20	1,30	1,50	1,60
40	16	100	0,92	1,10	1,40	1,60	1,80	2,10	2,30	2,50
50	20	100	1,40	1,80	2,10	2,50	2,90	3,20	3,60	3,90
63	20	100	2,30	2,90	3,50	4,10	4,70	5,30	5,90	6,40
80	25	100	3,80	4,70	5,70	6,60	7,60	8,50	9,50	10,40
100	25	100	6,00	7,50	9,00	10,50	12,00	13,50	15,00	16,60
125	32	100	9,40	11,80	14,10	16,40	18,80	21,10	23,50	25,80

Følg os på



[www.hncgroup.dk](http://www.hncgroup.dk)

**HNC**  
GROUP



Borgergade 17 | 4241 Vemmelev



7013 2300



[sales@hncgroup.dk](mailto:sales@hncgroup.dk)



[www.hncgroup.dk](http://www.hncgroup.dk)

HNC Group er en del af  
**momentum**  
group 

